

REVIEW OF DIGITAL COMMUNICATIONS

Notes prepared for EE 6328

by

Professor Cyrus D. Cantrell

January–May 2001

CONTENTS (1)

- Communication links
 - ▷ The good old days of telecom systems
 - ▷ Analog vs. digital communication
 - ▷ A communication link
 - ▷ Computer-to-computer link via the PSTN
 - ▷ Fully analog home-to-Internet link via the PSTN
 - ▷ Analog/digital home-to-Internet link via the PSTN
 - ▷ Logical vs. physical links
 - ▷ Physical channels
 - ▷ Point-to-point links
 - Datapath for a telephone call via the PSTN

CONTENTS (2)

- Properties of communication channels (start)
 - ▷ Transmission-line effects
 - Bounce diagram
 - Spice plot showing reflections on a transmission line
 - ▷ Attenuation
 - Attenuation in coaxial cable
 - Bandwidth depends on transmission distance
 - Attenuation in silica fiber
 - ▷ Crosstalk and noise
 - Near-end crosstalk
 - Attenuation to crosstalk ratio

CONTENTS (3)

- Properties of communication channels (end)
 - ▷ Intermodal dispersion
 - Details (1)
 - Details (2)
 - Details (3)
 - ▷ Group velocity dispersion
 - Details
 - GVD of selected single-mode fibers
 - Details for a bandwidth-limited pulse
 - Effect of self-phase modulation on the spectrum of a pulse

CONTENTS (4)

- Bandwidth usage of communication links
 - ▷ Baseband
 - Baseband (low-pass) spectrum
 - ▷ Broadband
 - Passband spectrum for 1 channel
 - Passband spectrum for more than 1 channel
 - Examples of broadband technologies
 - Concept of frequency division multiplexing
 - Concept of wavelength division multiplexing

CONTENTS (5)

- Digital communications
 - ▷ Why *digital* communications?
 - ▷ Single-duplex digital communication link
 - Physical effects on digital waveforms
 - Synchronization in digital communications
 - ▷ Full-duplex digital communication link
 - ▷ Eye patterns
 - ▷ Useful theorems from information theory
 - Source coding theorem
 - Channel capacity theorem
 - ▷ Bit error rate

CONTENTS (6)

- Time division multiple access (TDMA)
 - ▷ Digital transmission of analog signals: Example of North American PSTN
 - Pulse amplitude modulation (PAM)
 - Analog to digital conversion
 - Pulse code modulation (PCM)
 - Mu-law encoding
 - DS-1 frame
 - Channel bank–transmitting
 - Channel bank–receiving
 - ▷ TDMA technologies (1)
 - TDM signal hierarchy (North America, Japan, Korea)
 - TDM signal hierarchy (Europe—ITU)
 - SONET/SDH signal hierarchy
- TDMA technologies (2)

CONTENTS (7)

- Time division multiple access (TDMA) using packets
 - ▷ TDMA technologies (2)
 - Bandwidth-limited vs. transmission-limited packet links
 - Properties of physical links affect network architecture
 - Scale vs. type of interconnection
- References

THE “GOOD OLD DAYS” OF TELECOM SYSTEMS

- Analog voice circuit between customer and central office
 - ▷ Maximum frequency transmitted: 4 kHz
 - ▷ Carried on a single twisted copper-wire pair
- Inter-central-office trunks:
 - ▷ Required repeaters every 2 km
 - ▷ Duct diameter (10 cm) limited the number of circuits
- Temporary solution: DS-1 (*Digital Signal Type 1*) signals
 - ▷ 1.544 Mbits/s (24 time-multiplexed voice channels plus 8 kbits/s overhead)
 - ▷ T-1 carrier systems used since 1962: DS-1 carried on twisted pair wires, with repeaters every 2 km to remove electromagnetic crosstalk & to compensate for attenuation ($\propto \sqrt{\text{frequency}}$ due to skin effect)

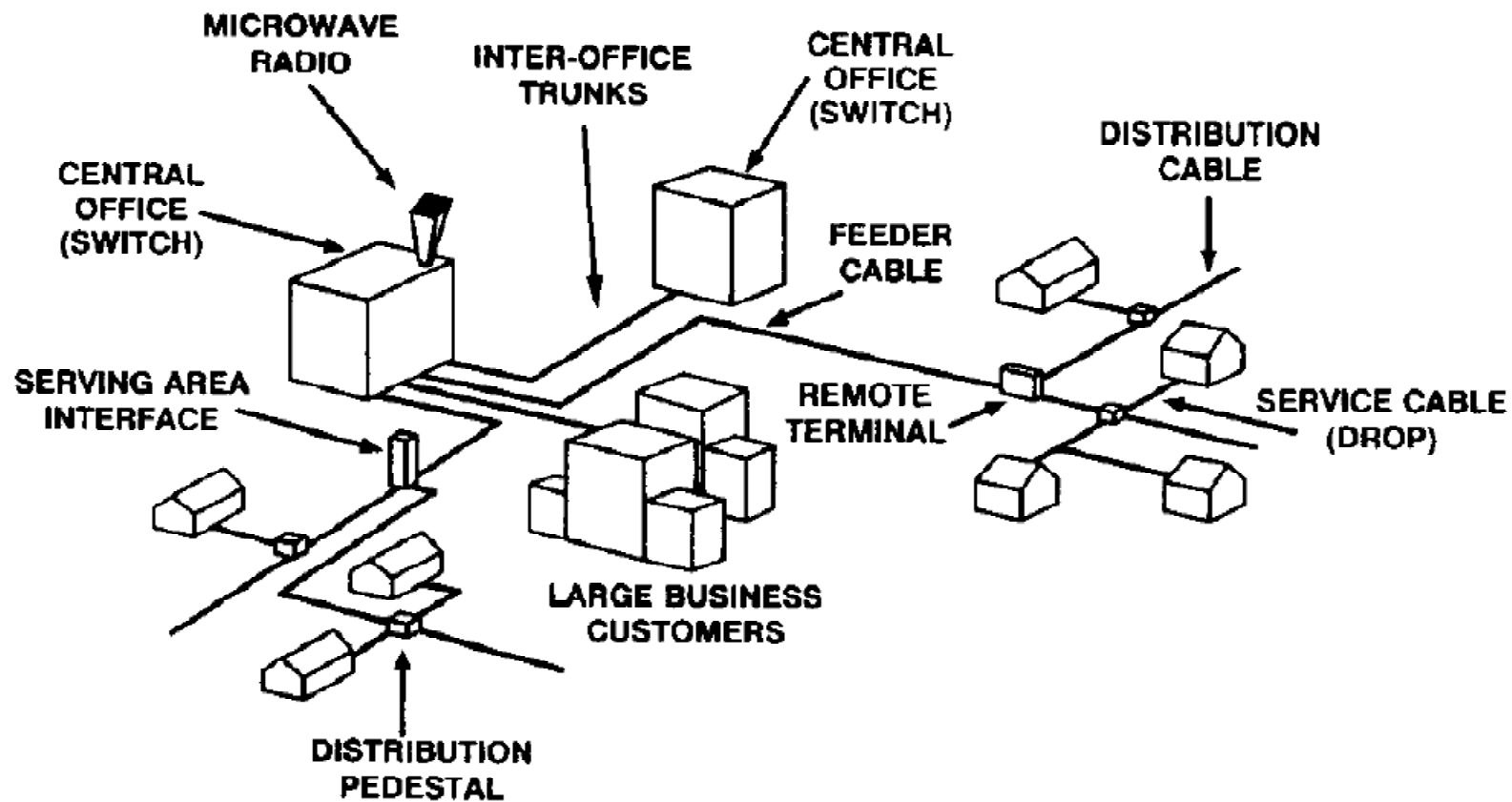

FIRST-GENERATION FIBEROPTIC TELECOM SYSTEMS

- Purpose:
 - ▷ Eliminate repeaters in T-1 systems used in inter-office trunk lines
- Technology:
 - ▷ 0.8 μm GaAs semiconductor lasers
 - ▷ Multimode silica fibers
- Limitations:
 - ▷ Fiber attenuation
 - ▷ Intermodal dispersion
- Deployed since 1974

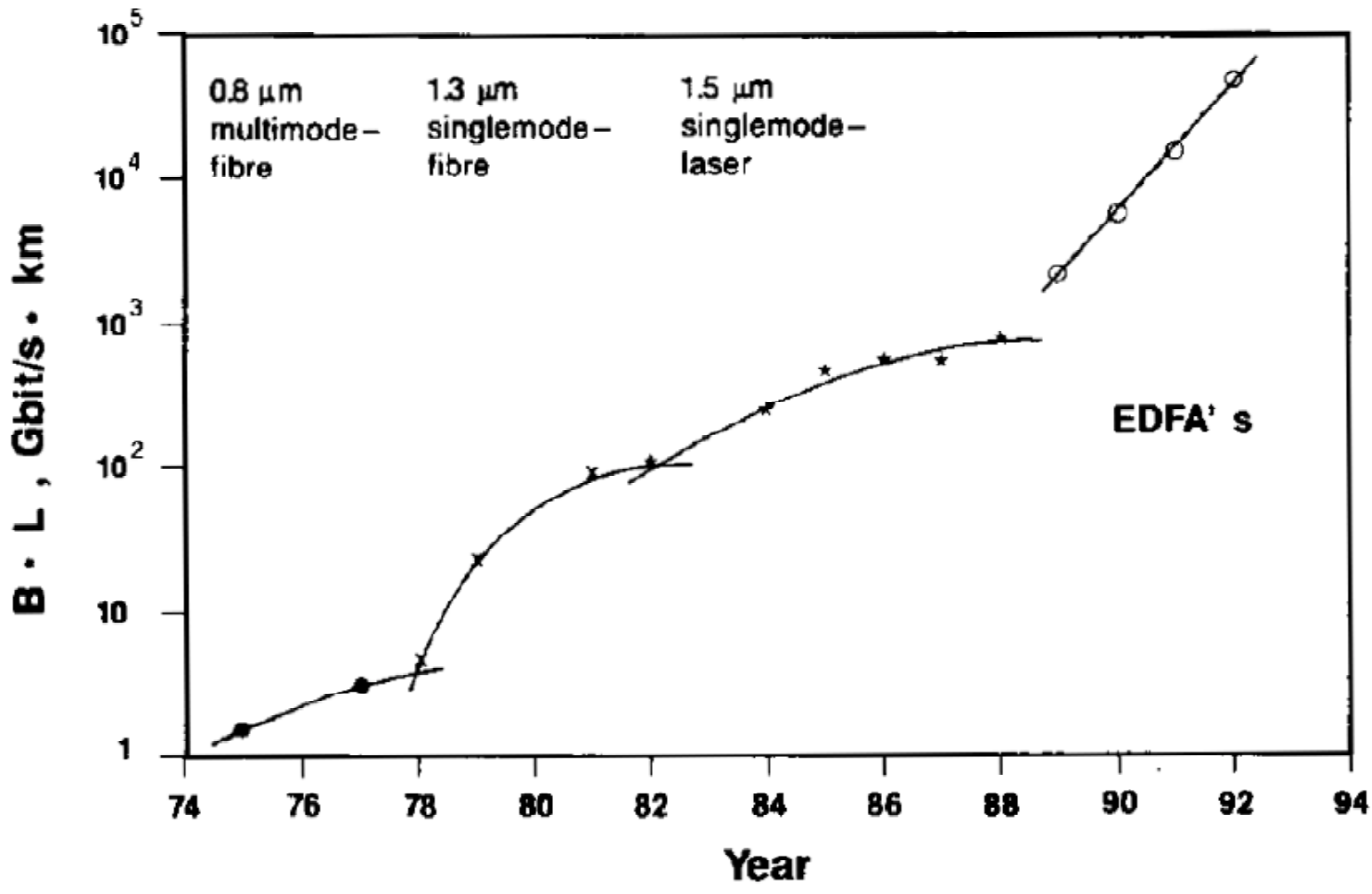

SECOND-GENERATION FIBEROPTIC TELECOM SYSTEMS

- Opportunity:
 - ▷ Development of low-attenuation fiber (removal of H₂O and other impurities)
 - ▷ Eliminate repeaters in long-distance lines
- Technology:
 - ▷ 1.3 μm multi-mode semiconductor lasers
 - ▷ Single-mode, low-attenuation silica fibers
 - ▷ DS-3 signal: 28 multiplexed DS-1 signals carried at 44.736 Mbits/s
- Limitation:
 - ▷ Fiber attenuation (repeater spacing \approx 6 km)
- Deployed since 1978

THIRD-GENERATION FIBEROPTIC TELECOM SYSTEMS

- Opportunity:
 - ▷ Deregulation of long-distance market
- Technology:
 - ▷ 1.55 μm single-mode semiconductor lasers
 - ▷ Single-mode, low-attenuation silica fibers
 - ▷ OC-48 signal: 810 multiplexed 64-kb/s voice channels carried at 2.488 Gbits/s
- Limitations:
 - ▷ Fiber attenuation (repeater spacing \approx 40 km)
 - ▷ Fiber dispersion
- Deployed since 1982

FOURTH-GENERATION FIBEROPTIC TELECOM SYSTEMS

- Opportunity:
 - ▷ Development of erbium-doped fiber amplifiers
- Technology (deployment began in 1994):
 - ▷ 1.55 μm single-mode, narrow-band semiconductor lasers
 - ▷ Single-mode, low-attenuation, dispersion-shifted silica fibers
 - ▷ Frequency-division multiplexing of 4 or more 2.488 Gbits/s signals
- **Nonlinear effects** limit the following system parameters:
 - ▷ Signal launch power
 - ▷ Propagation distance without regeneration/reclocking
 - ▷ WDM channel separation
 - ▷ Maximum number of WDM channels per fiber

ANALOG vs. DIGITAL COMMUNICATION

- **Analog communication** uses continuous-time signals that:
 - ▷ Can (in principle) take any real value
 - ▷ When received, produce an output that also varies continuously
 - ▷ Degrade gradually in the presence of physical effects such as attenuation, dispersion, low bandwidth, or noise
 - A high point of analog communication technology:
The superheterodyne receiver
- **Digital communication** uses continuous-time signals that:
 - ▷ Represent bits or bit groups using a finite, standard alphabet
 - Continuous-time inputs are sampled, giving discrete-time series that are digitized and encoded before being transmitted
 - ▷ When received, produce an output that is interpreted as bits or bit groups
 - ▷ Can be “cleaned up” from some distortion and noise, but generally do not degrade gracefully below a minimum signal-to-noise ratio
- In simple words, digital is profoundly different from analog

A COMMUNICATION LINK

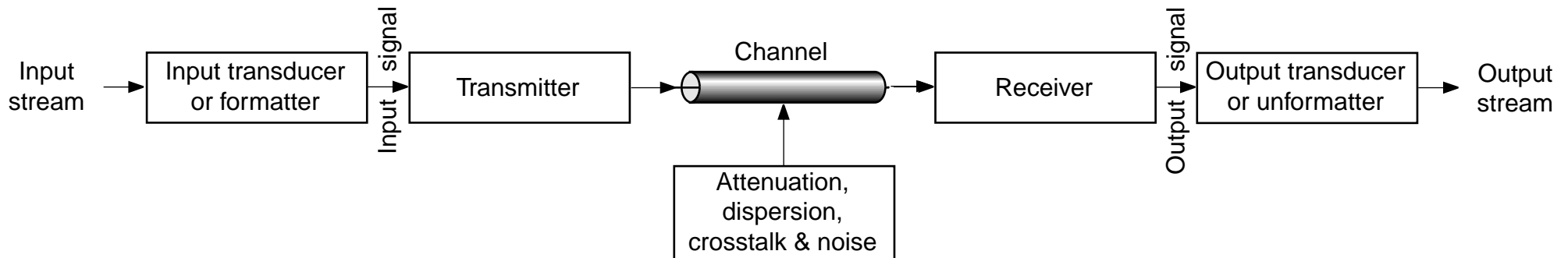

Transfer function:

$$G(\omega) = G_T(\omega)G_C(\omega)G_R(\omega)$$

- The diagram applies to both analog and digital links
 - ▷ For a digital link, the analog part is the transmitter, channel and receiver
 - ▷ For a linear, time-shift-invariant link, the transfer function defines the bandwidth, total attenuation and dispersion from transmitter input to receiver output

Computer-to-computer link via the PSTN (U.S.)

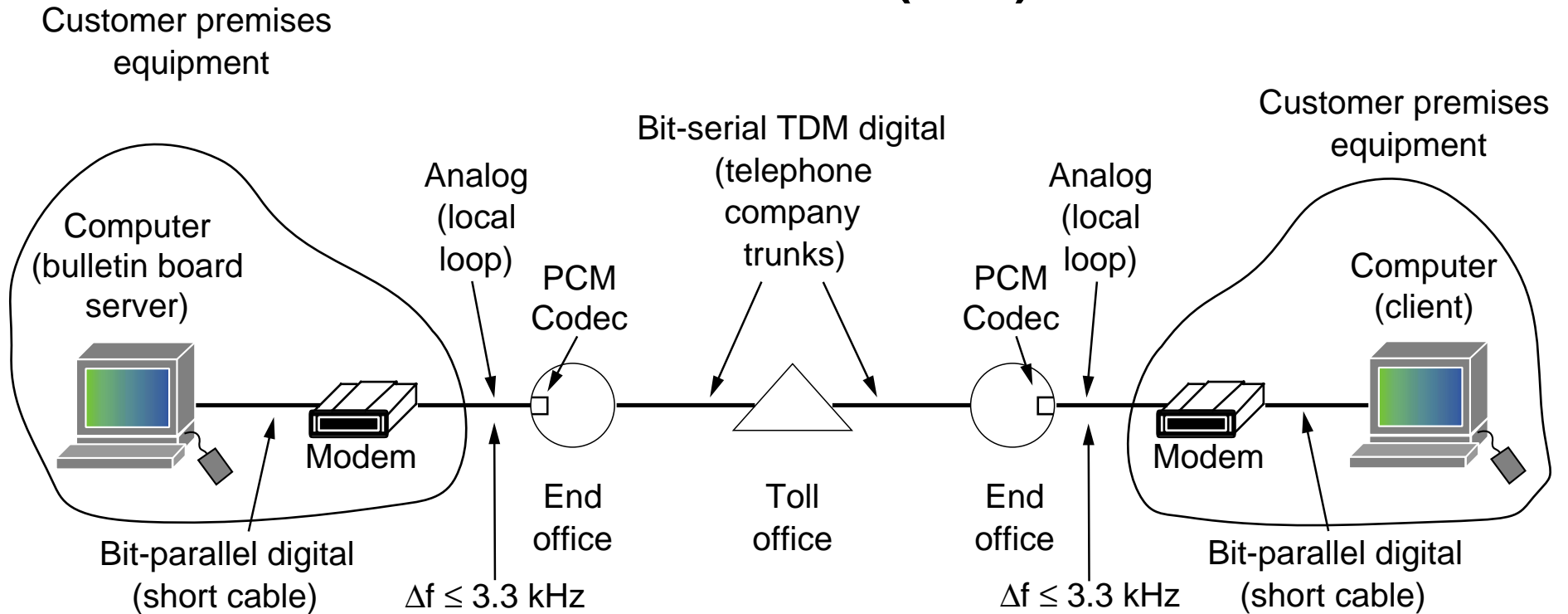

Fully analog home-to-Internet link via the PSTN (U.S.)

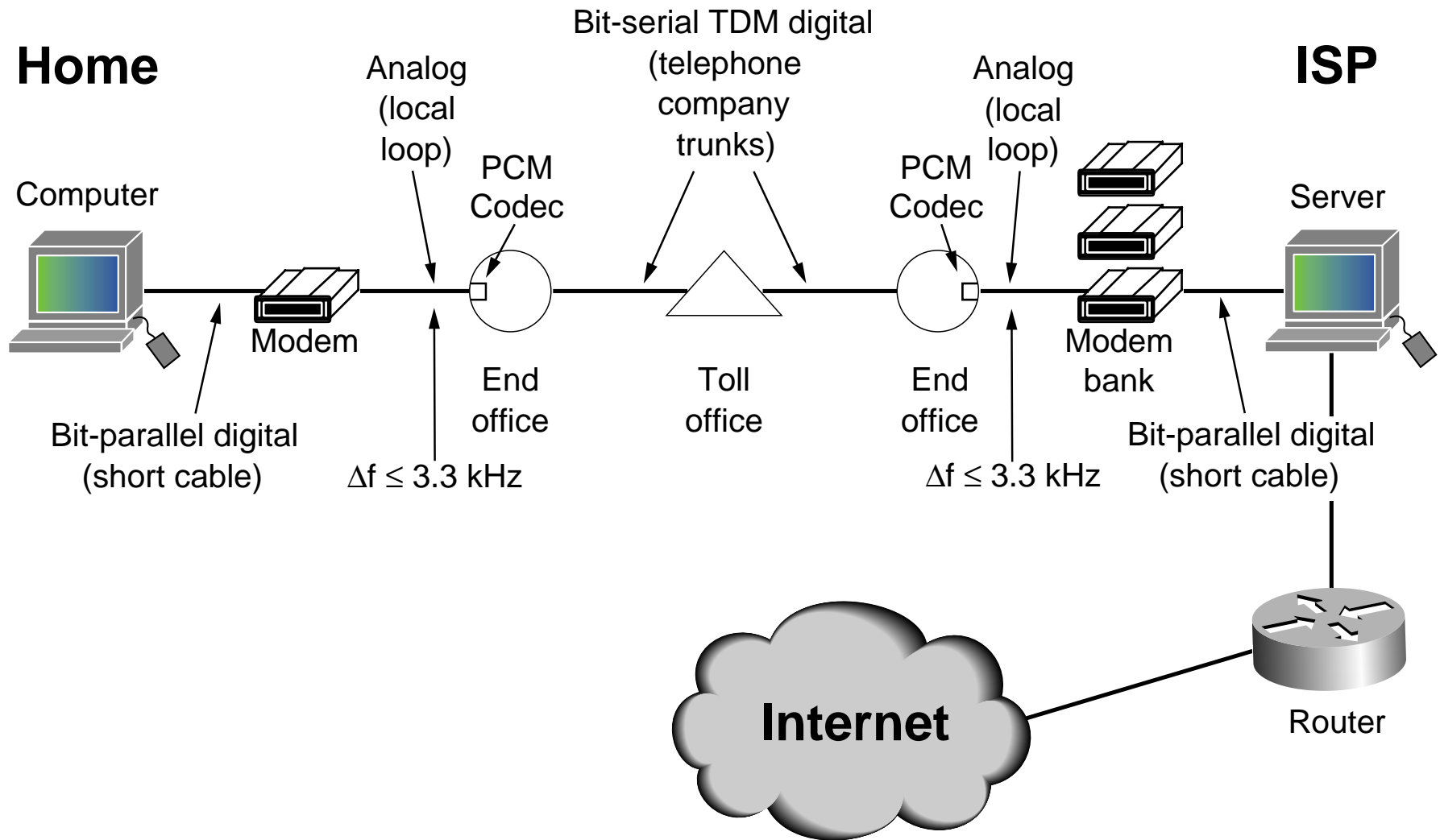

Analog/digital home-to-Internet link via the PSTN (U.S.)

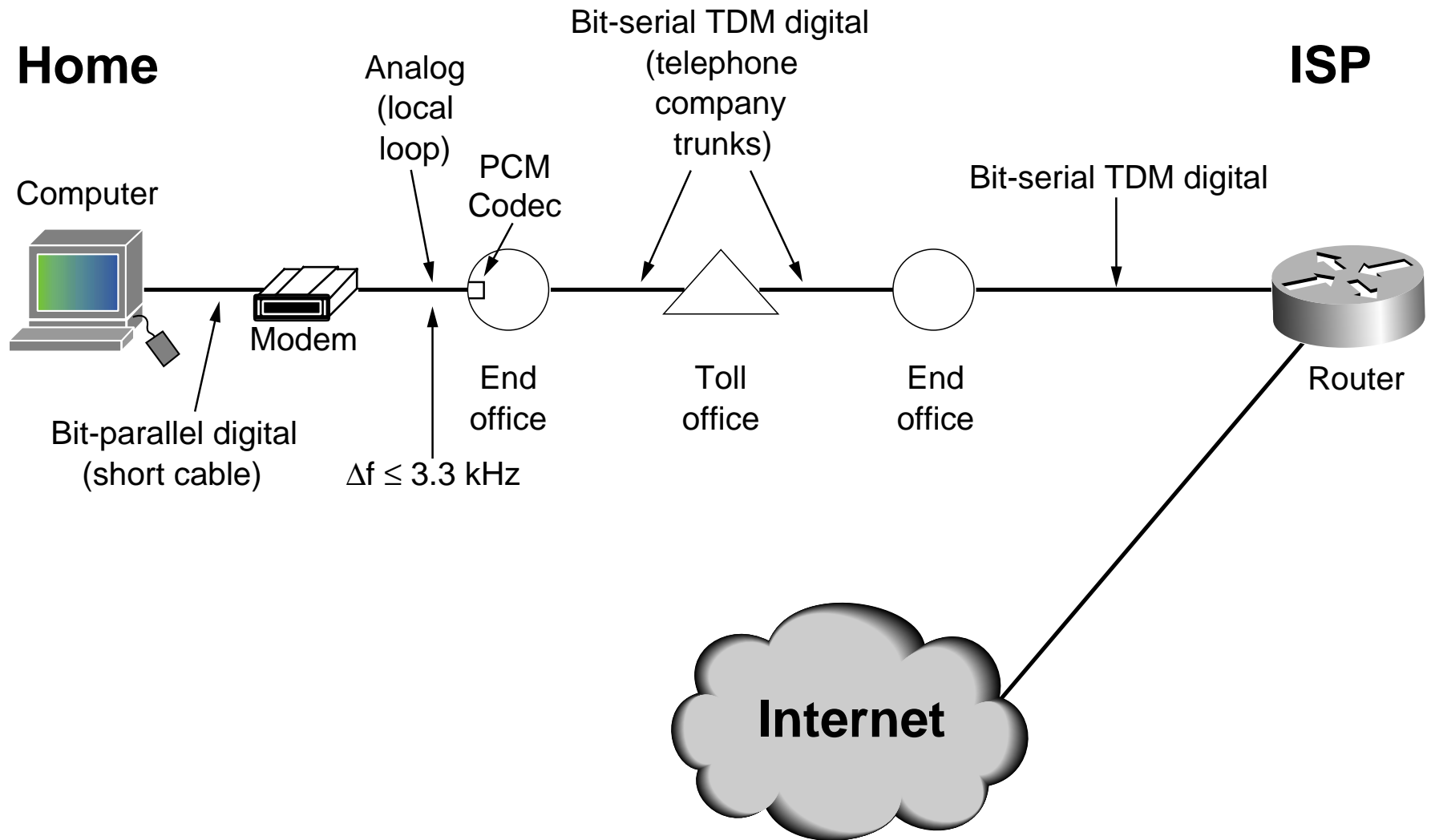

LOGICAL vs. PHYSICAL LINKS

- Physical channels can be baseband or broadband
 - ▷ A broadband channel can share the medium with other physical channels
- Each physical channel supports one or more logical links
 - ▷ If several logical links originate at one host, one speaks of **multiplexing** the logical links onto the physical link
 - ▷ If several logical links originate from different hosts, one speaks of **multiple access** to the physical link

PHYSICAL CHANNELS

- Types of physical channels that support data communication:
 - ▷ Point-to-point: A channel between exactly two hosts (or one host and one peripheral device)
 - Examples:
 - ◇ Cable connection from PC serial port to printer
 - ◇ Crossover cable Ethernet connection between two PCs
 - ◇ Telephone call set up between a home PC and an ISP's server
 - ▷ Multipoint: A channel shared by more than two hosts or peripherals
 - Examples:
 - ◇ An external SCSI bus
 - ◇ An external USB or Firewire bus
 - ◇ An Ethernet
 - ◇ A wireless LAN

POINT-TO-POINT LINKS

- A **point-to-point link** uses a physical channel between two only 2 host computers over which information can be transmitted
 - ▷ Channels are transmission lines or waveguides
 - Linear, time-shift-invariant systems (for most purposes)
 - ▷ Main physical properties for purposes of communication:
 - Bandwidth
 - Maximum transmission distance
 - ▷ Electrical/electromagnetic properties that determine data bandwidth and maximum transmission distance:
 - Delay
 - Transmission-line effects
 - Attenuation
 - Crosstalk and noise
 - Differential mode delay
 - Group velocity dispersion

Datapath for a telephone call via the PSTN (U.S.)

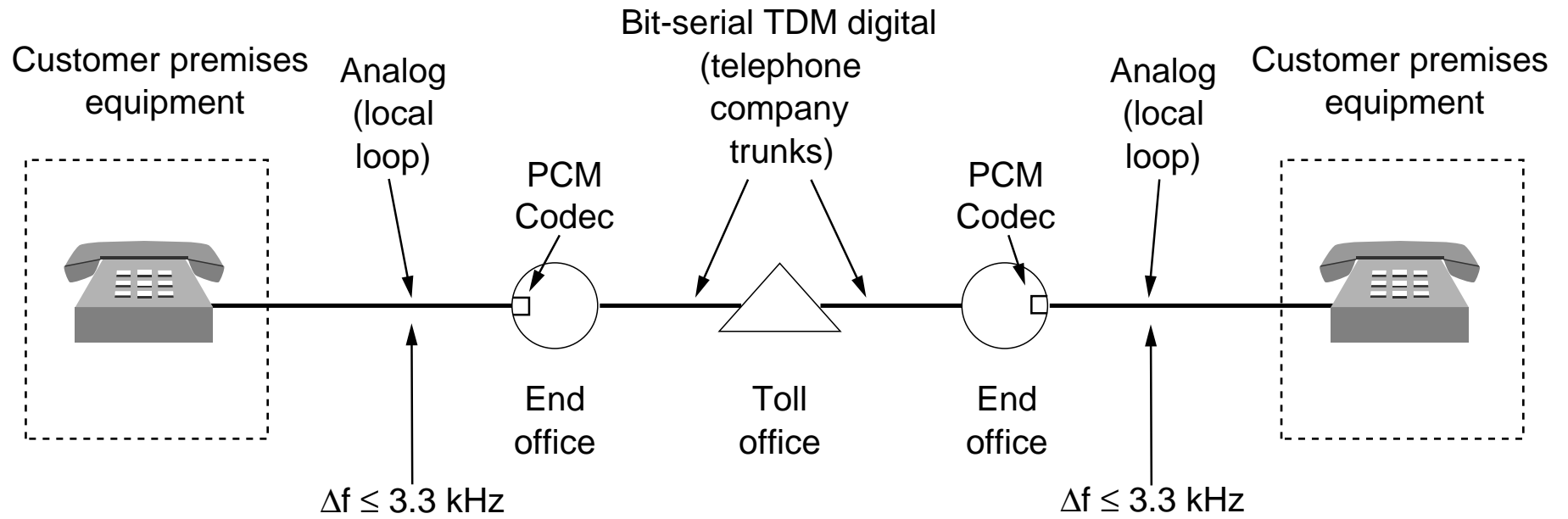

PROPERTIES OF COMMUNICATION CHANNELS (1)

- **Delay**

- ▷ **Propagation time:**

$$\text{(propagation time across a channel of length } L) = \frac{L}{v_g}$$

- v_g is the **group velocity**, i.e., the velocity of a pulse
 - v_g is usually almost equal to the **phase velocity**, i.e., the velocity of a theoretical monochromatic wave of infinite duration

- ▷ **Transmission time**

$$\text{(transmission time for } N \text{ bits into a channel of bandwidth } \Delta f) = \frac{N}{\Delta f}$$

- ▷ **Total delay**

$$\begin{aligned} \text{total delay} = & \text{transmission time} + \text{propagation time} \\ & + \text{buffering time} + \text{processing time} \end{aligned}$$

PROPERTIES OF COMMUNICATION CHANNELS (2)**• Transmission-line effects****▷ Characteristic impedance:**

$$Z_0 = \sqrt{\frac{L}{C}}$$

- If the line is terminated with an impedance Z_L that is not equal to Z_0 , then energy is reflected back towards the transmitter
- Improperly terminated lines may be unusable for communications

▷ Reflection coefficient:

$$\rho = \frac{Z_L - Z_0}{Z_L + Z_0}$$

- Reflections can be analyzed in the time domain by using a bounce diagram

Visualization of a pulse on a transmission line using a bounce diagram

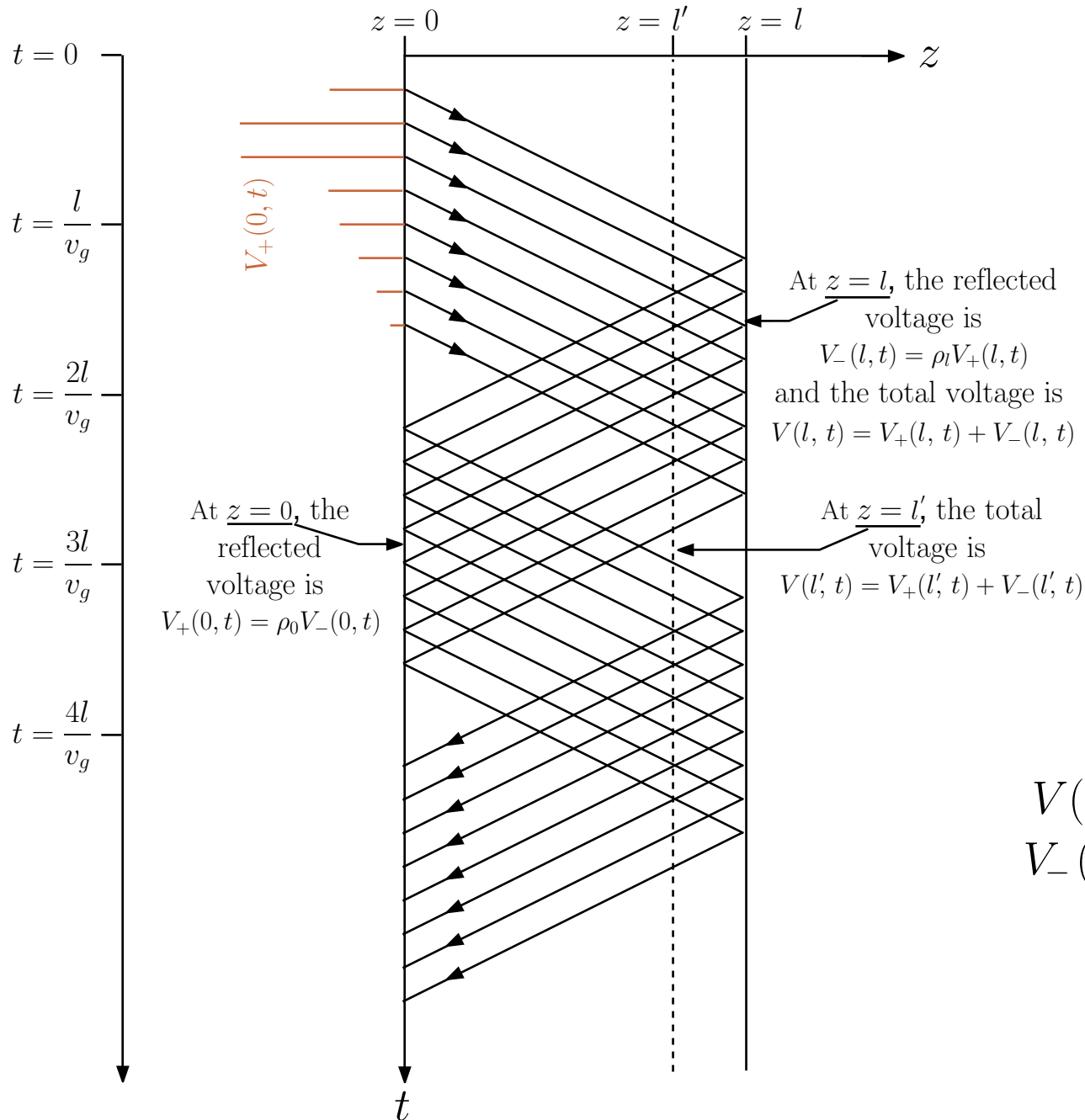

Basic equations:

$$V(z, t) = V_+(z, t) + V_-(z, t)$$

$$V_-(l, t) = \rho_l V_+(l, t)$$

$$\rho = \frac{Z_L - Z_0}{Z_L + Z_0}$$

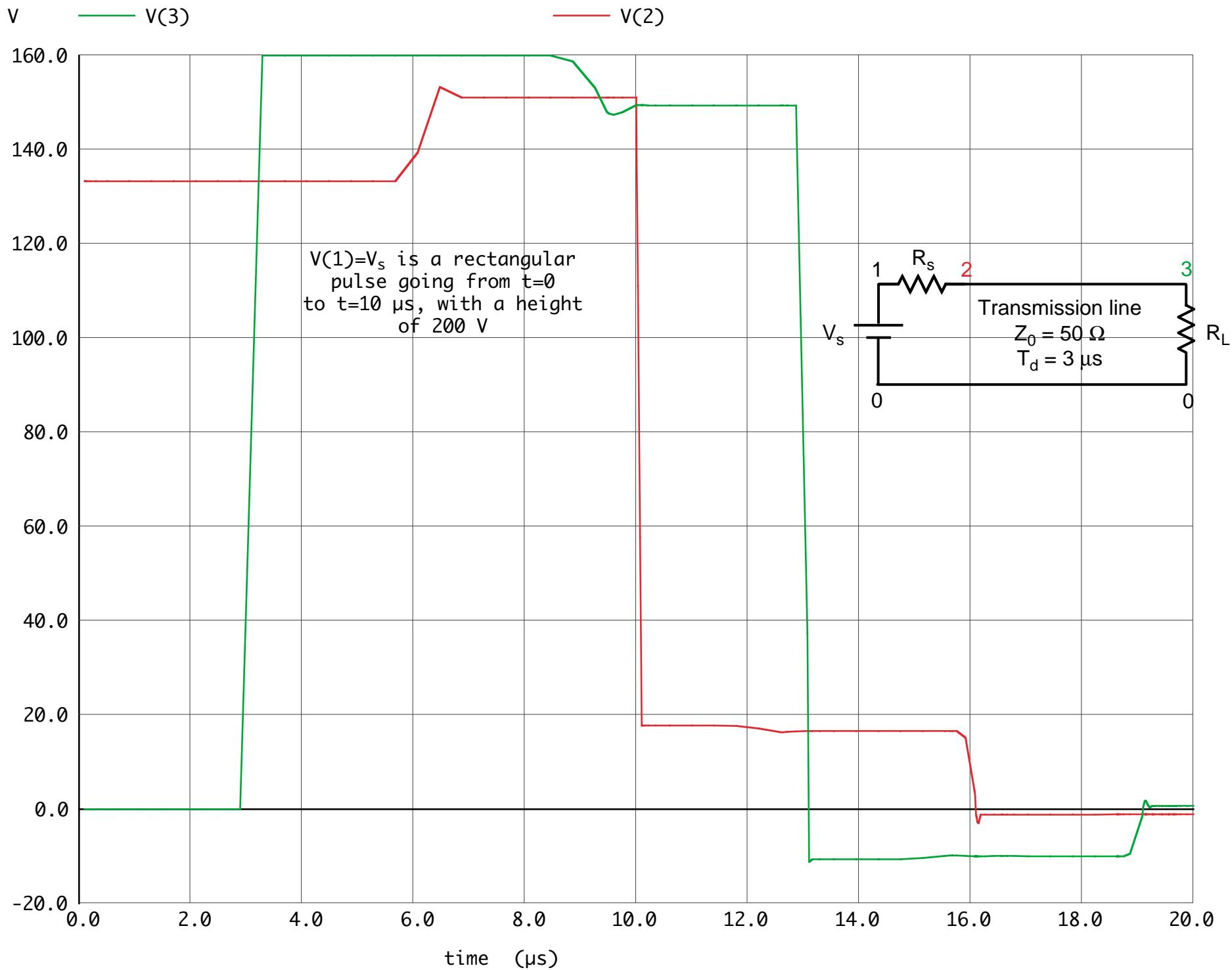

PROPERTIES OF COMMUNICATION CHANNELS (3)

• Attenuation

$$\frac{\text{Power received at a distance } L \text{ from the transmitter}}{\text{Power transmitted}} = e^{-\alpha L}$$

- ▷ α is the **attenuation coefficient** (units are cm^{-1} or m^{-1})
- ▷ Loss in dB = $10(\log_{10} e)\alpha L \approx 4.343 \alpha L$
- ▷ Practical units of the attenuation coefficient are dB/km or dB/m
- ▷ In metallic transmission lines, α depends on the frequency f , mainly because of the skin effect
 - Skin depth $\delta(f) = 1/\sqrt{\pi f \mu \sigma}$
 - For a coaxial transmission line with inner radius r_i and outer radius r_o ,

$$\alpha(f) \approx \frac{R_s(f)}{2\eta \ln(r_o/r_i)} \left(\frac{1}{r_o} + \frac{1}{r_i} \right) \text{ m}^{-1}$$

where the surface resistance is

$$R_s(f) = \sqrt{\frac{\pi f \mu}{\sigma}} \text{ ohms}$$

ATTENUATION IN COAXIAL CABLE

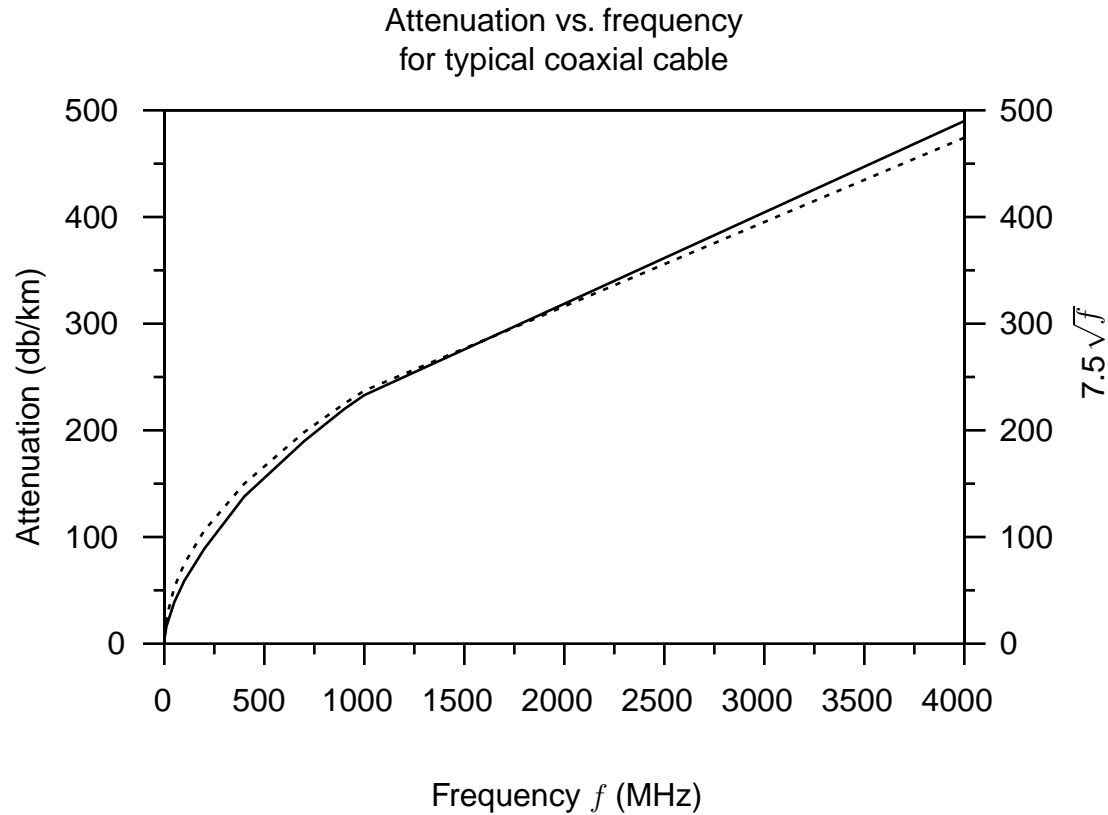

- The dashed line shows a constant times \sqrt{f}

BANDWIDTH DEPENDS ON TRANSMISSION DISTANCE

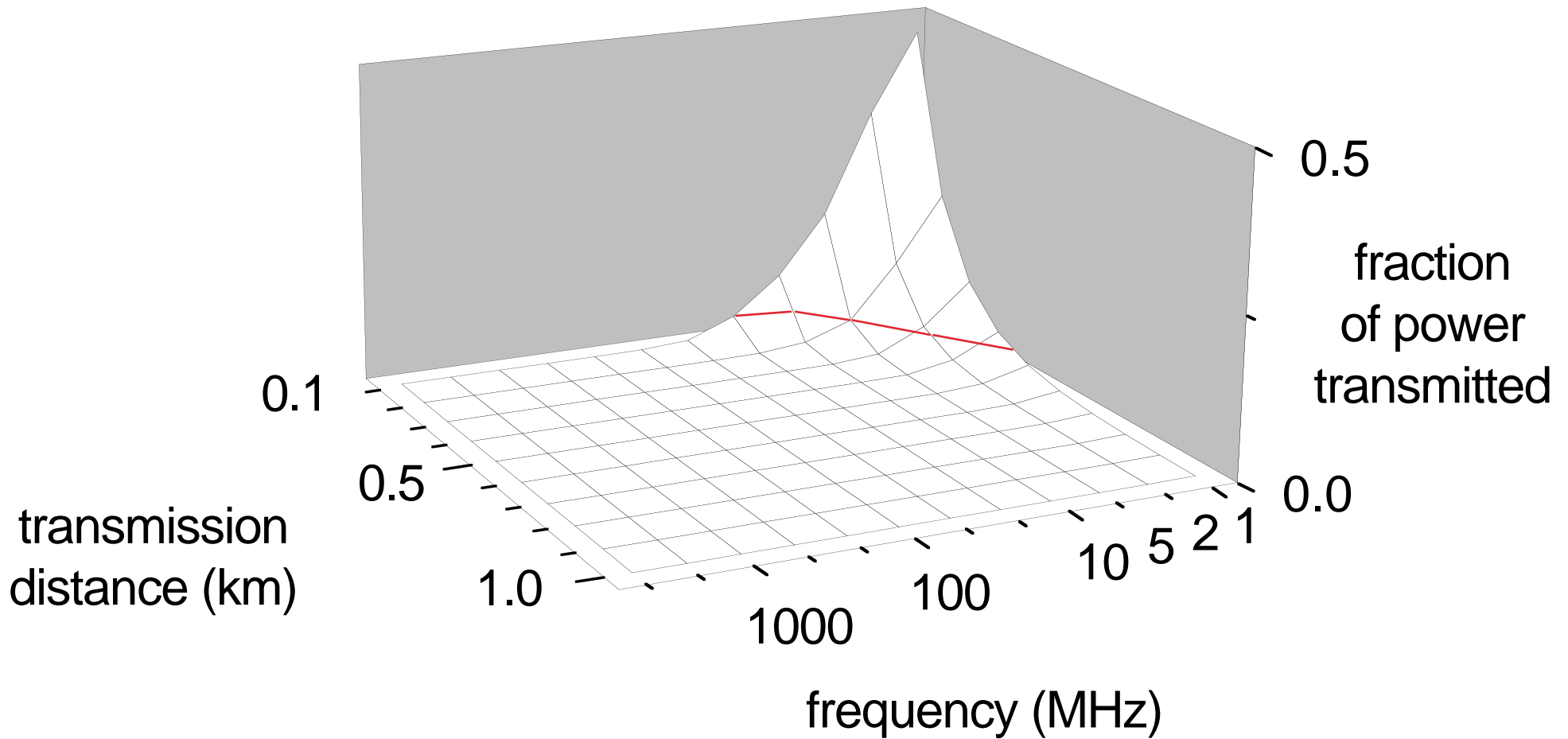

- The red curve indicates a constant value of attenuation

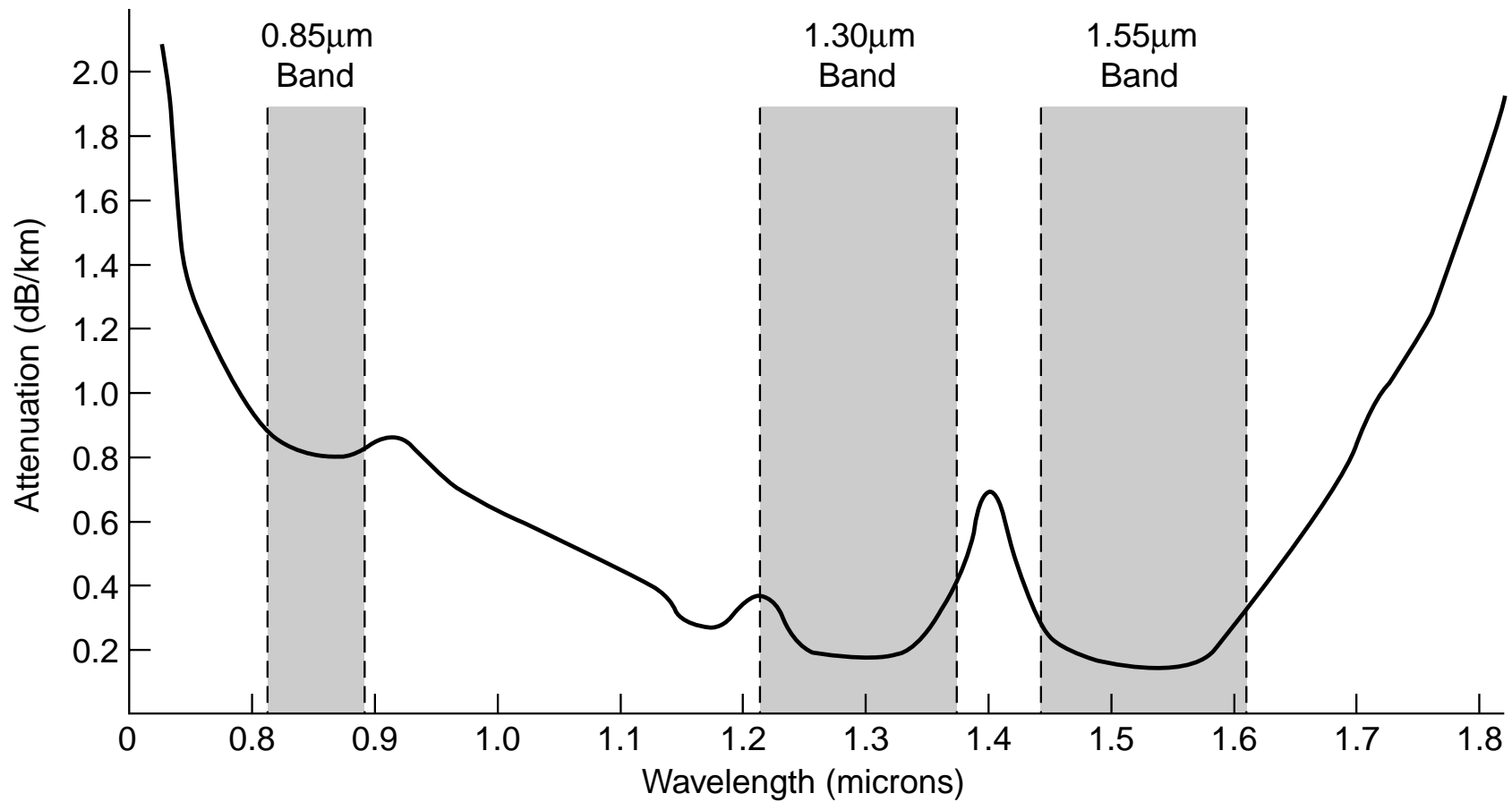

Attenuation of light in silica fiber in the near-infrared region

PROPERTIES OF COMMUNICATION CHANNELS (4)

- **Crosstalk**

- ▷ Crosstalk = unwanted waveforms induced in a channel by waveforms in adjacent channels
- ▷ Crosstalk cannot be cancelled easily, because a crosstalk waveform is not related to the transmitted waveform in the target channel
- ▷ Origin in electrical transmission lines: (Mostly) capacitive coupling
 - Inductive or radiative coupling may occur at high frequencies
- ▷ Crosstalk between WDM channels in fiber is due to cross-phase modulation or 4-wave mixing

- **Noise**

- ▷ Information is carried by a pulse train or an analog waveform
- ▷ **Bit error rate** = probability that a waveform that was transmitted as a 1 bit will be detected as representing a 0 bit (or vice versa)

NEAR END CROSSTALK (NEXT)

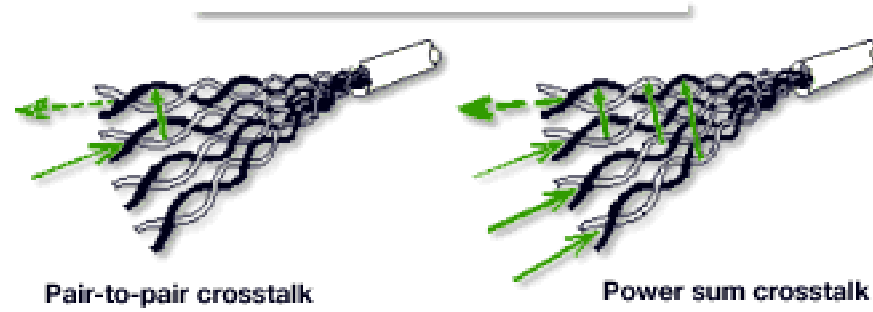
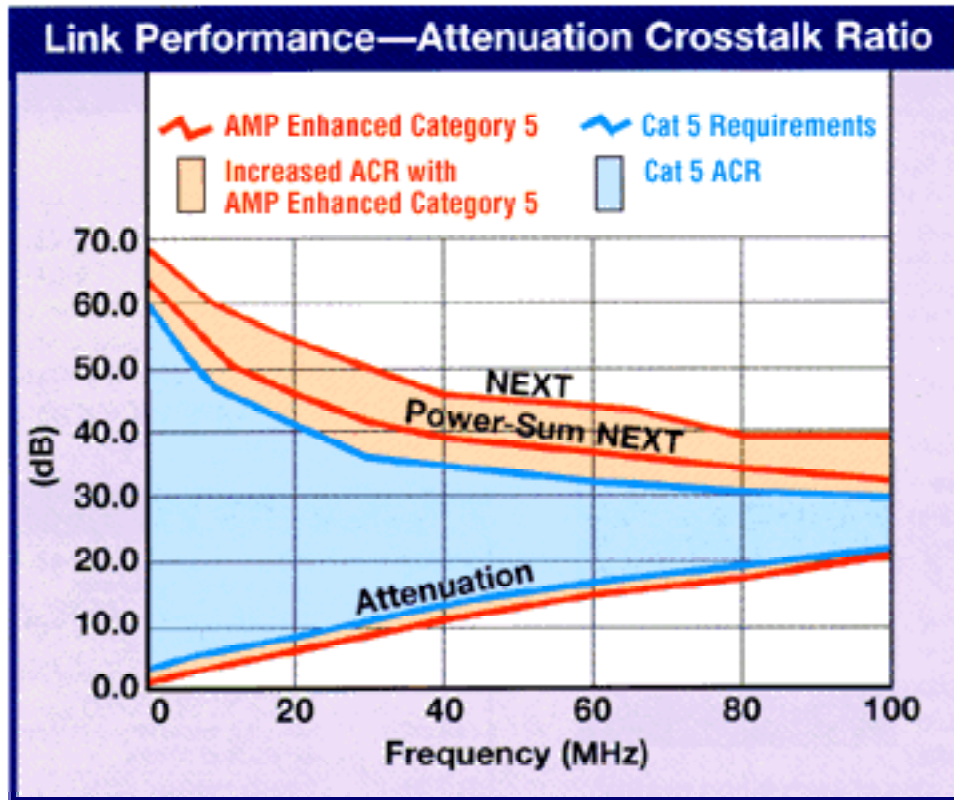
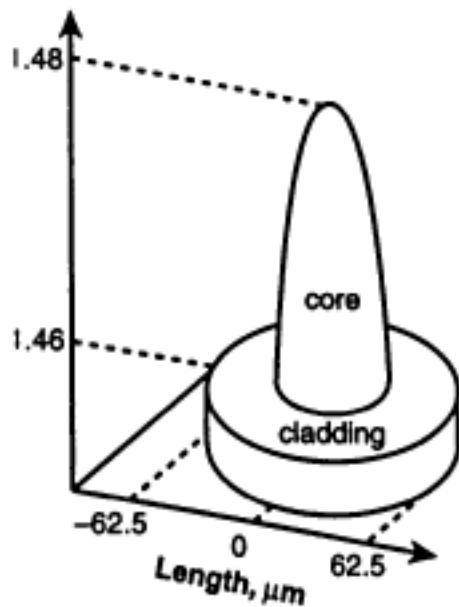

Figure 1 - Near End Crosstalk

ATTENUATION TO CROSSTALK RATIO





Graded index multimode fiber

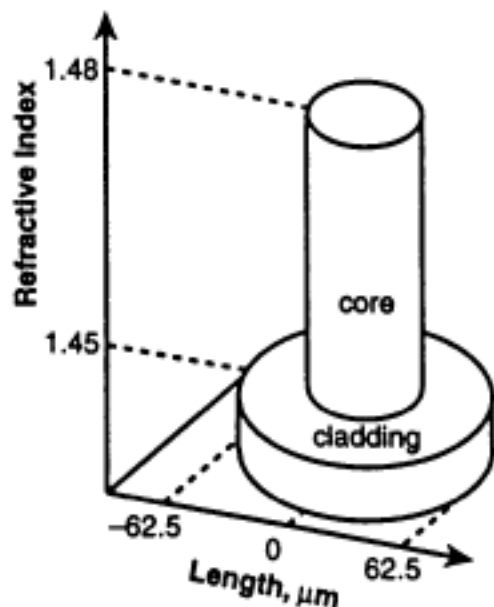

Step index multimode fiber

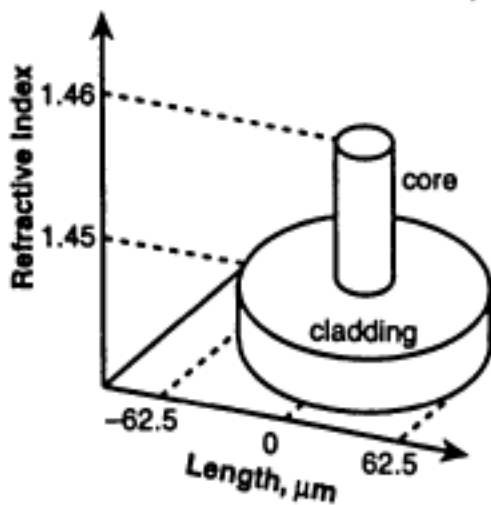

Single-mode fiber

PROPERTIES OF COMMUNICATION CHANNELS (5)

• Intermodal dispersion

- ▷ Different **modes** of propagation in a waveguide correspond to different **E** and **H** field patterns
 - For a fiber with a sufficiently small core radius, there is only one propagating mode
- ▷ Different modes propagate at different speeds because some modes take a longer path through a fiber than others
- ▷ The **differential mode delay**

$$\frac{L_1}{v_c} - \frac{L_2}{v_c} \quad (\text{units: } \mu\text{s, ns or ps})$$

is the difference in arrival times of two pulses launched into different modes

- $v_c \approx c/n_{\text{core}}$ is the propagation velocity of a monochromatic wave in the core of the fiber
- ▷ Differential mode delay is important for LAN technologies

INTERMODAL DISPERSION (1)

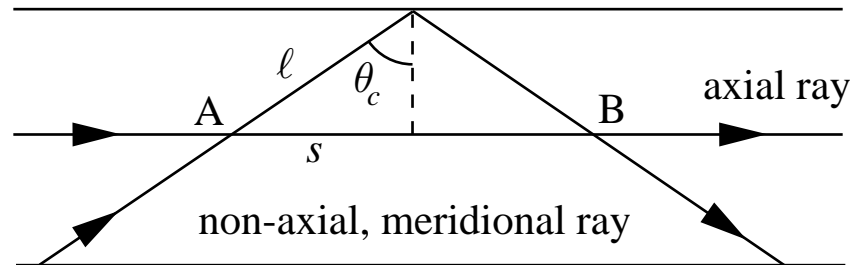

- $\ell = \frac{s}{\sin \theta_c}$ where $\theta_c =$ critical angle and $\sin \theta_c = \frac{n_{\text{clad}}}{n_{\text{core}}}$
- For a fiber of length L , the difference in arrival times is

$$\begin{aligned} \Delta t &= \frac{n_{\text{core}} L}{c} \left(1 - \frac{1}{\sin \theta_c} \right) \\ &= \left(\frac{n_{\text{core}} L}{c} \right) \left(\frac{n_{\text{core}}}{n_{\text{clad}}} \right) \Delta \end{aligned}$$

$$\text{where } \Delta = \frac{n_{\text{core}} - n_{\text{clad}}}{n_{\text{core}}}$$

INTERMODAL DISPERSION (2)

- For a fiber of length L , the difference in arrival times of a pulse that travels along an axial ray and one that travels along a meridional ray at the critical angle is

$$\begin{aligned}\Delta t &= \frac{n_{\text{core}}L}{c} \left(1 - \frac{1}{\sin \theta_c} \right) \\ &= \left(\frac{n_{\text{core}}L}{c} \right) \left(\frac{n_{\text{core}}}{n_{\text{clad}}} \right) \Delta\end{aligned}$$

$$\text{where } \Delta = \frac{n_{\text{core}} - n_{\text{clad}}}{n_{\text{core}}}$$

- ▷ Numerical value for $n_{\text{core}} \approx n_{\text{clad}} \approx 1.5$ and $\Delta \approx 3 \times 10^{-3}$:

$$\frac{\Delta t}{L} \approx 15 \text{ ns/km}$$

INTERMODAL DISPERSION (3)

- Requirement for minimal intersymbol interference:

$$B \Delta t < 1$$

where

$$B = \text{bit rate}$$

- ▷ Maximum length bit-rate product:

$$BL < \frac{n_{\text{clad}} c}{n_{\text{core}}^2 \Delta}$$

- ▷ Numerical values for $n_{\text{core}} \approx n_{\text{clad}} \approx 1.5$:

- Clad multimode fiber ($\Delta \approx 3 \times 10^{-3}$): $BL < 67 \text{ Mb-km/s}$
- Unclad multimode fiber ($\Delta \approx .33$): $BL < .4 \text{ Mb-km/s}$

PROPERTIES OF COMMUNICATION CHANNELS (6)**• Group velocity dispersion**

- ▷ The **phase velocity** of a wave, $v_p = \omega/\beta$, is the velocity at which a monochromatic wave travels
- ▷ The **group velocity**, $v_g = d\omega/d\beta$, is the velocity of a pulse
 - A pulse is a superposition of many frequencies, by Fourier analysis
 - If ω is not a linear function of β , then $v_g \neq v_p$
- ▷ The differential group delay, $d(L/v_g)$, is the difference in arrival times of:
 - Two pulses centered at different wavelengths, or
 - The high-wavelength and low-wavelength parts of a single pulse

$$\frac{1}{L} \frac{d(L/v_g)}{d\lambda} = \text{DGD per unit distance, per unit wavelength difference}$$

- **Chromatic dispersion:**

$$D := \frac{d(1/v_g)}{d\lambda} \quad (\text{units: ps per nm-km})$$

(a)

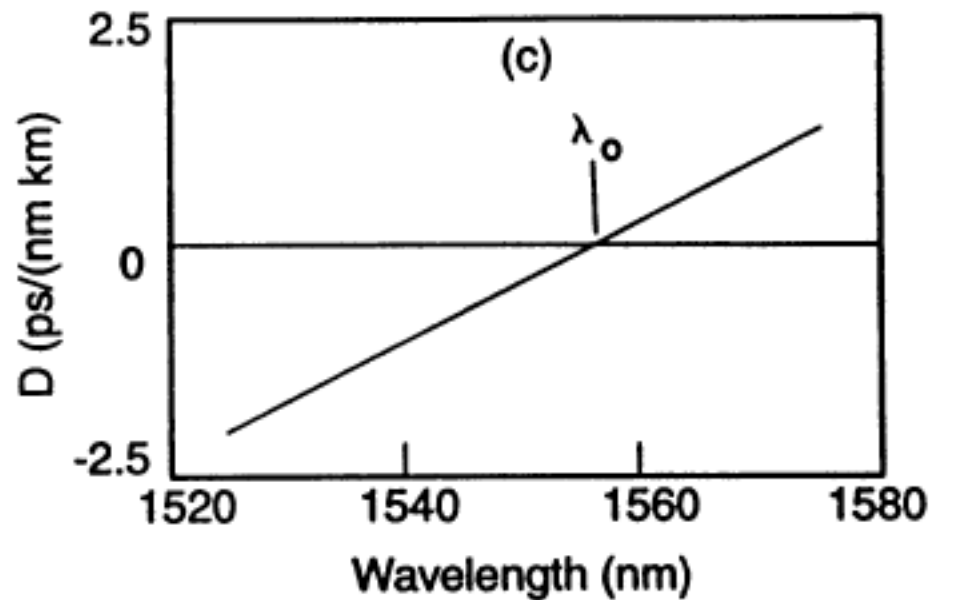
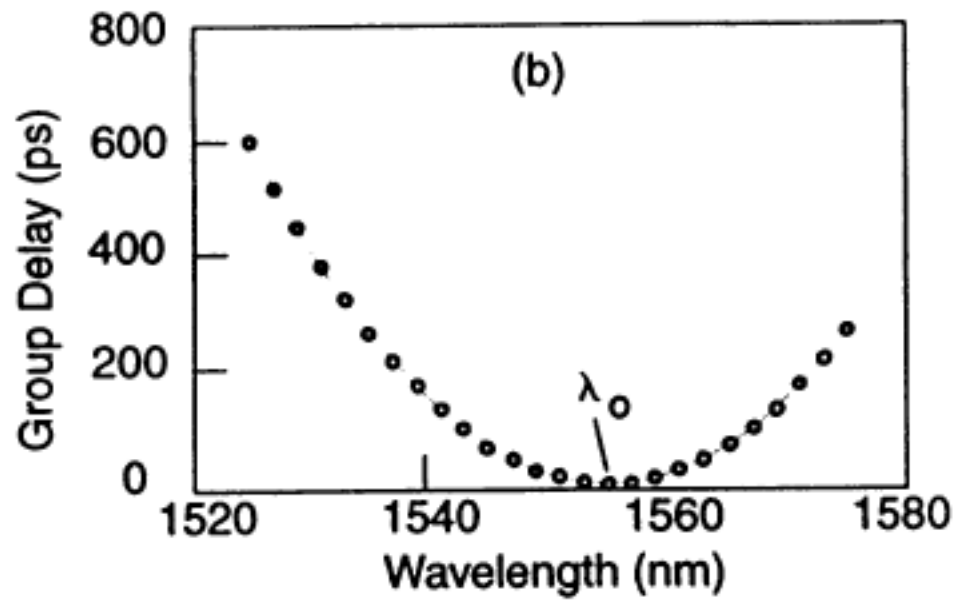
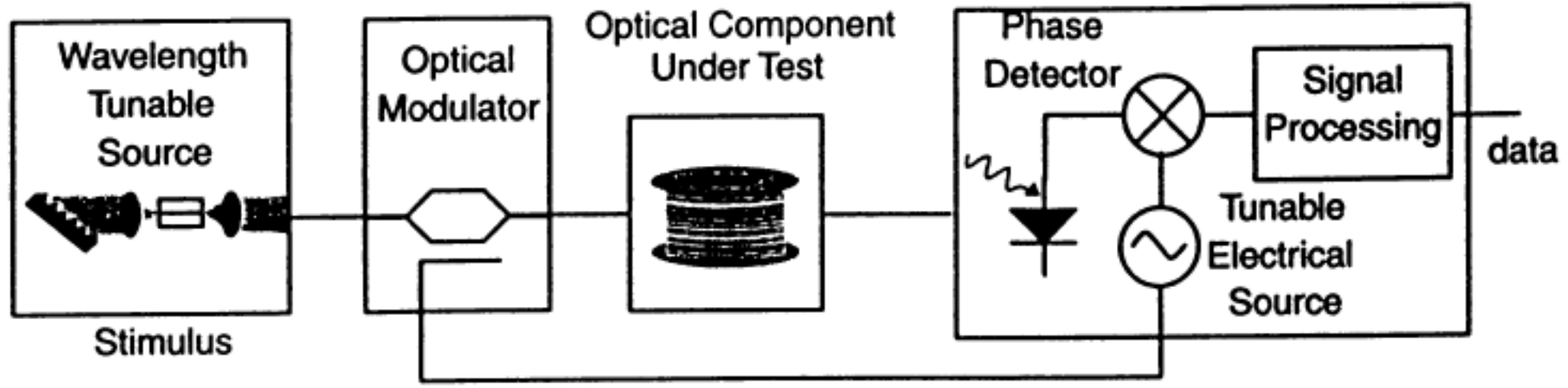

Figure 1.14 (a) Chromatic dispersion measurement of two-port optical devices. (b) Relative group delay versus wavelength. (c) Dispersion parameter versus wavelength.

GROUP VELOCITY DISPERSION IN SINGLE-MODE FIBER (1)

- Difference in arrival times of waves at wavelengths λ and $\lambda + \Delta\lambda$:

$$\Delta t = L \frac{d}{d\lambda} \left(\frac{1}{v_g} \right) \Delta\lambda$$

$$= LD \Delta\lambda$$

$$D = D_M + D_W$$

▷ Material dispersion: $D_M = \frac{1}{c} \frac{dn_{2g}}{d\lambda} = -\frac{2\pi}{\lambda^2} \frac{dn_{2g}}{d\omega}$

▷ Waveguide dispersion: $D_W = -\frac{2\pi\Delta}{\lambda^2} \left[\frac{n_{2g}^2}{n_{2\omega}} - V \frac{d^2(Vb)}{dV^2} + \frac{dn_{2g}}{d\omega} \frac{dVb}{dV} \right]$

- Requirement for minimal intersymbol interference:

$$B \Delta t < 1 \Rightarrow BL|D|\Delta\lambda < 1$$

DISPERSION OF SINGLE-MODE FIBERS

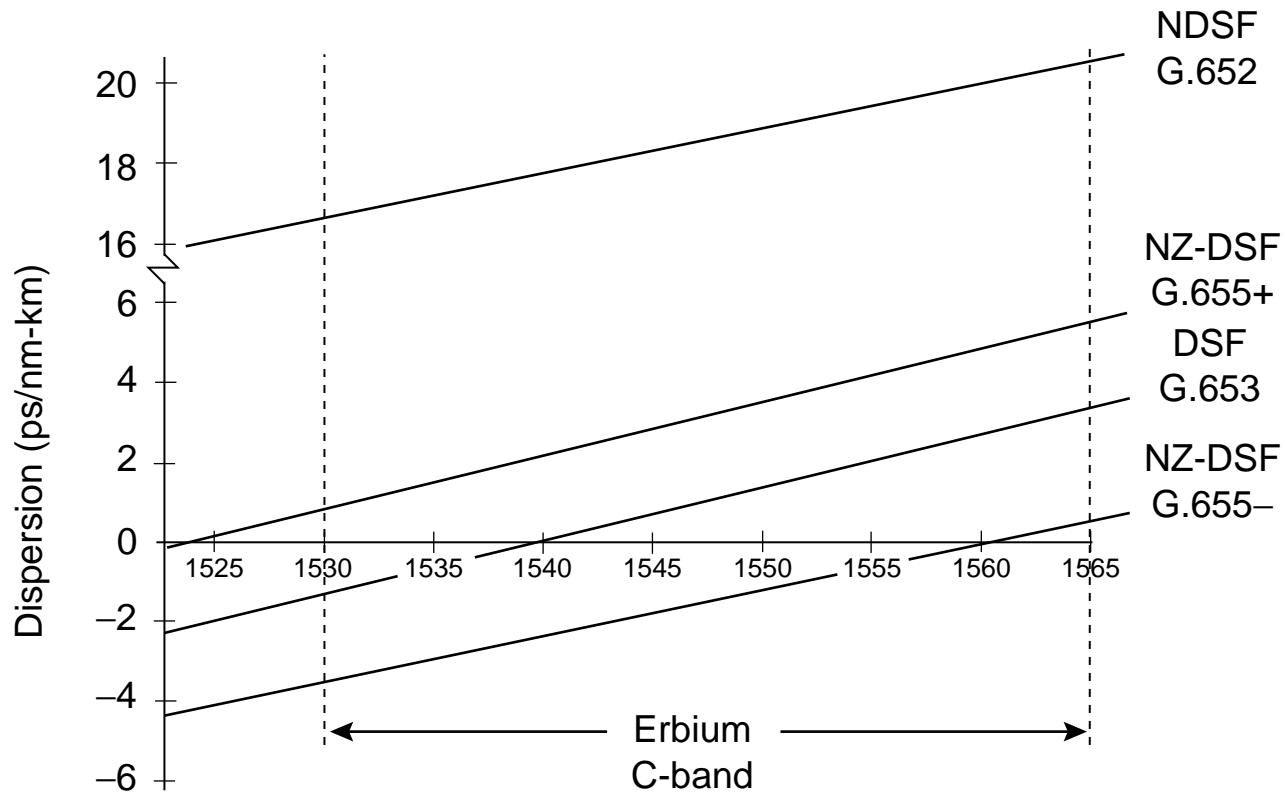

GROUP VELOCITY DISPERSION IN SINGLE-MODE FIBER (2)

- Wavelength spread $\Delta\lambda$ for a pulse:

$$\left| \frac{\Delta\lambda}{\lambda} \right| = \left| \frac{\Delta\nu}{\nu} \right| \Rightarrow |\Delta\lambda| = \frac{\lambda^2}{v} |\Delta\nu|$$

- ▷ The Fourier integral theorem (applied to a Gaussian waveform) says that $|\Delta\nu| \cdot |\Delta t| \approx 1$. Then, for a bandwidth-limited pulse,

$$|\Delta\nu| \approx B$$

- ▷ For a non-bandwidth-limited pulse,

$$|\Delta\nu| > B \Rightarrow |\Delta\lambda| > B \frac{\lambda^2}{v}$$

- Requirement for minimal intersymbol interference:

$$BL < \frac{1}{|D| \cdot |\Delta\lambda|} < \frac{v}{B|D|\lambda^2} \Rightarrow \boxed{B^2L < \frac{v}{|D|\lambda^2}}$$

GROUP VELOCITY DISPERSION IN SINGLE-MODE FIBER (3)

- Which criterion should one use to determine the maximum bit rate B that an optical channel can carry,

$$BL < \frac{1}{|D| \cdot |\Delta\lambda|} \quad \text{or} \quad B^2L < \frac{v}{|D|\lambda^2} \quad ?$$

- ▷ The first criterion (on BL) should be applied when the source is a broadband laser or an LED. In this case, the width of the signal in wavelength or frequency is independent of the bit rate.
- ▷ The second criterion (on B^2L) should be applied when the laser source is narrowband, and the signal is created by externally modulating the laser light (using on-off keying). In this case, the bandwidth of the signal is due almost entirely to the finite duration of the pulses created by external modulation.
 - The frequency width of a pulse may change as the pulse propagates, as a result of **self-phase modulation**

DISPERSION: SUMMARY

- Dispersion limits the bandwidth and length of a fiber communication link by causing pulses to spread in time as they propagate down the fiber
 - ▷ Bit rate and modulation format determine the signal's average spectrum
 - ▷ The spectrum and the dispersion determine the difference in arrival times of different frequency components of a pulse
 - ▷ The spread in arrival times is (approximately) linear in distance
 - If the spread in arrival times exceeds the duration of a bit slot, intersymbol interference occurs
 - ▷ For a given dispersion and propagation distance, there is a maximum bit rate
 - ▷ For a given bit rate and dispersion, there is a maximum propagation distance

EFFECT OF SELF-PHASE MODULATION ON THE SPECTRUM OF A PULSE

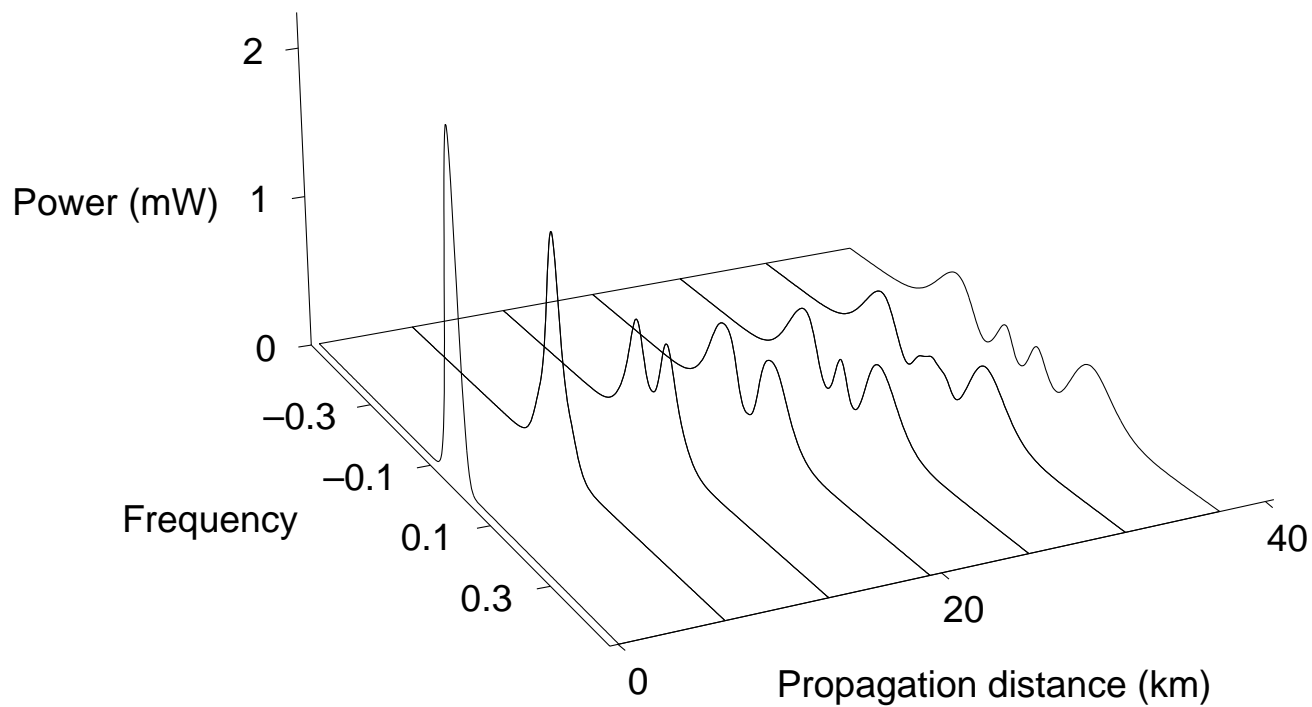

LASERS FOR COMMUNICATIONS

- Oscillator = amplifier with positive feedback and enough gain to cancel loss
- Edge-emitting lasers
 - ▷ Fabry-Pérot (CD-type) lasers
 - Feedback occurs through reflection at the end surfaces
 - Each Fabry-Pérot mode has a unique wavelength λ , such that

$$2n_c L = m\lambda \quad \text{for some integer } m$$

where n_c is the refractive index of the laser medium

- More than one Fabry-Pérot mode lies under the gain curve
 - ▷ Distributed-feedback lasers
 - Feedback occurs through Bragg reflection from gratings
- Vertical-cavity surface-emitting lasers (VCSELs)
 - ▷ Feedback occurs through reflection from multilayer mirrors
 - ▷ Modes are widely spaced \Rightarrow usually only one mode under the gain curve

AN EARLY FABRY-PEROT LASER

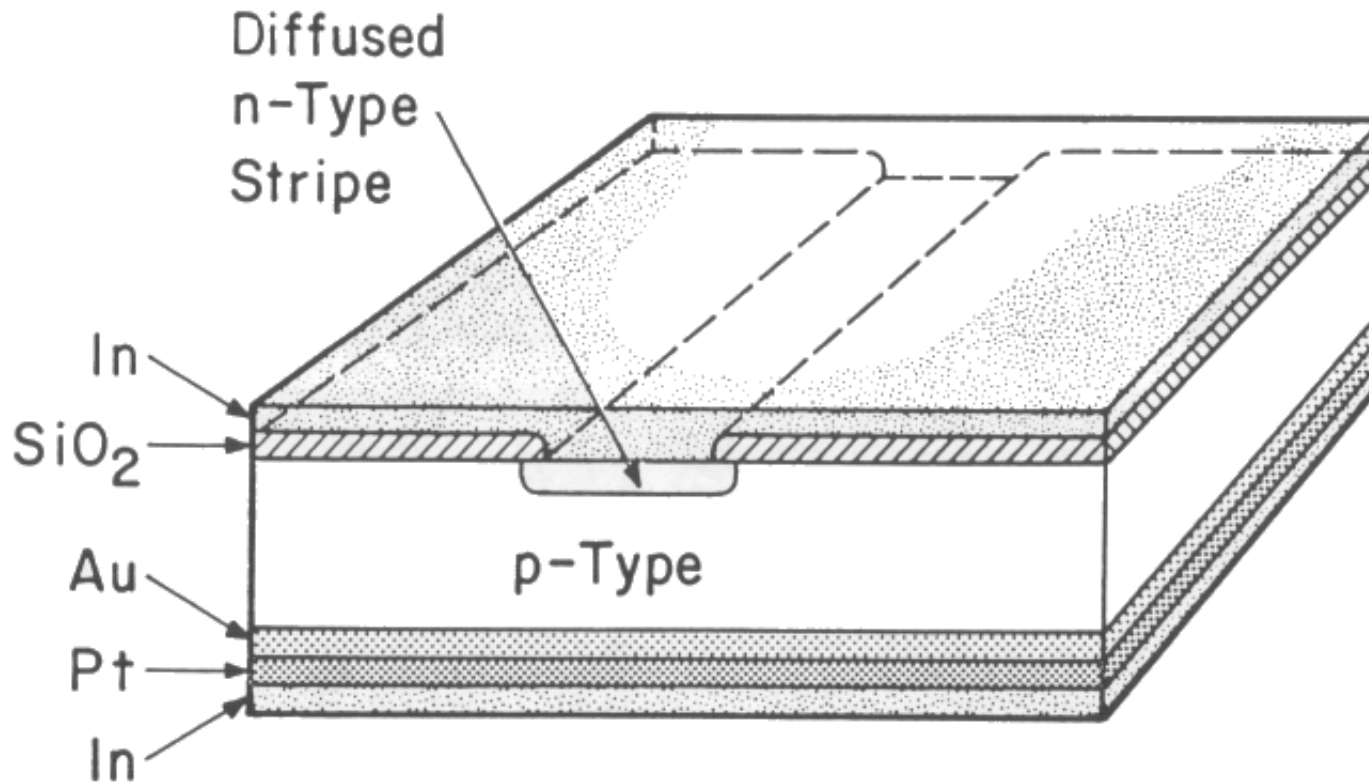

VERTICAL-CAVITY SURFACE-EMITTING LASER

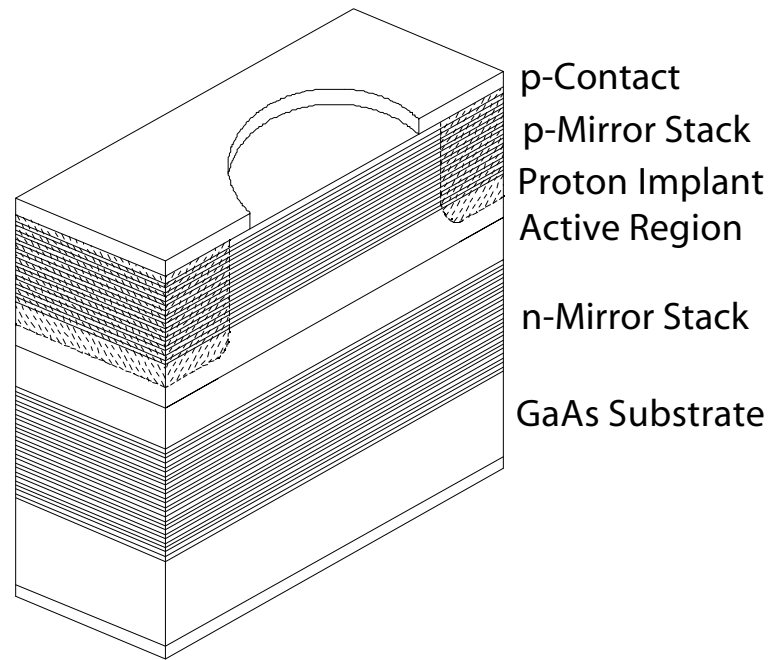

VCSEL Chip Structure

ARRAY OF VCSELS

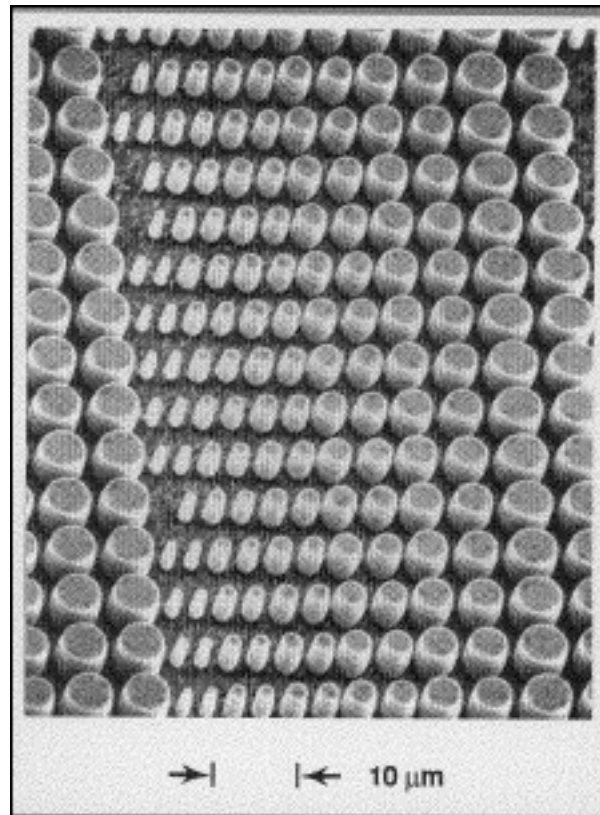

MODAL NOISE (SPECKLE NOISE)

- Occurs in multimode fiber systems (systems in which there are multiple guided modes)
- A result of:
 - ▷ Mode-dependent loss
 - Example: Offset splice or connection
 - ▷ Fluctuations in time of the distribution of energy among different guided modes, or of the relative phases of different modes

Modal Noise: Causes 1

- Spatial modes *propagating* in a multimode fiber *interfere* and create *speckle pattern*:

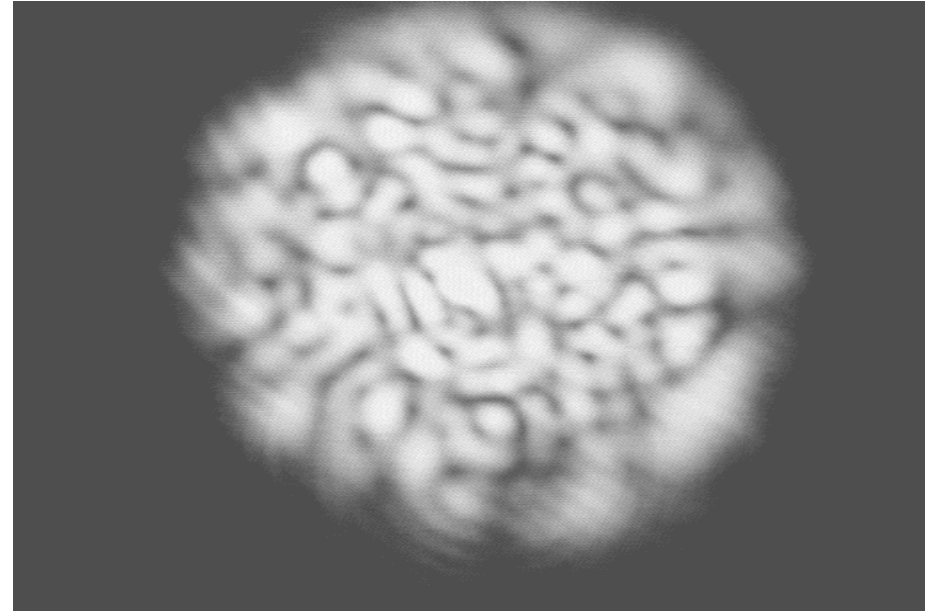
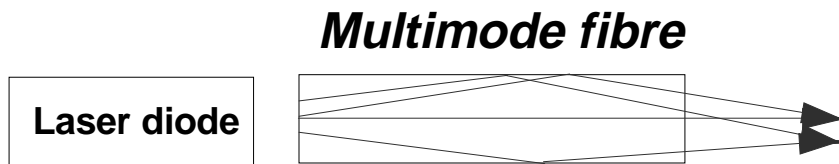

- *Speckle pattern* at fibre end *changes with time*

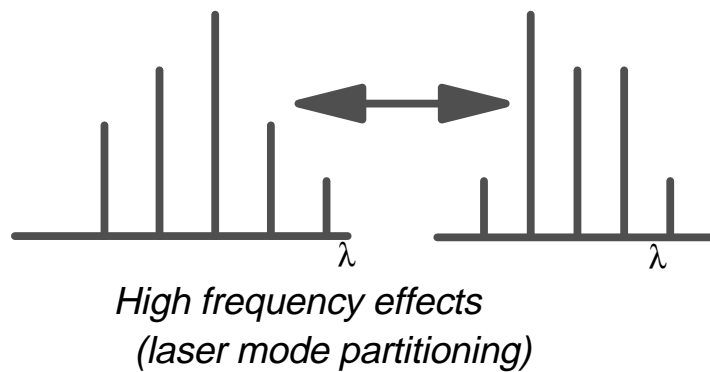

Low frequency effects:
vibrations
temperature changes

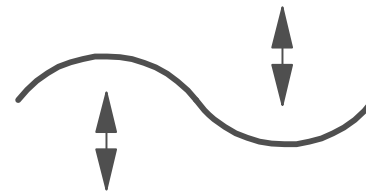

Modal Noise: Causes 2

- Imperfect connectors, splices create ***mode selective loss (MSL)***

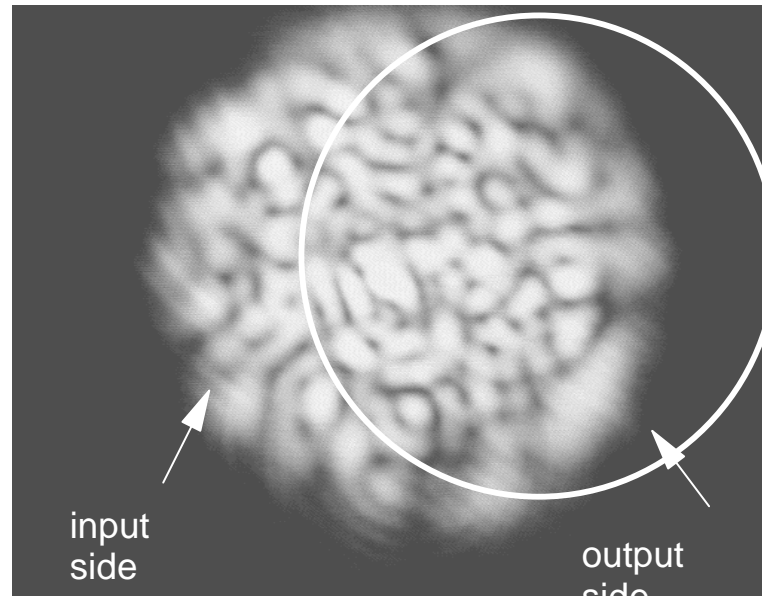

With the changing speckle pattern, the amount of power lost in the mode selective element varies, creating ***amplitude noise*** at the receiver.

The amount of modal noise depends on:

1. *Coherence of the light source*
2. *Fiber bandwidth*
3. *Amount of the mode selective loss*

MODE PARTITION NOISE

- CD-type lasers operate in more than one Fabry-Pérot mode

- ▷ Each Fabry-Pérot mode has a unique wavelength λ , such that

$$2n_c L = m\lambda \quad \text{for some integer } m$$

where n_c is the refractive index of the laser medium

- Don't confuse the laser's Fabry-Pérot modes with fiber modes!
- ▷ Although the total laser power remains constant in time, the distribution of power among the available Fabry-Pérot laser modes fluctuates in time
 - Power radiated into a single-mode fiber by laser modes that differ in wavelength by $\Delta\lambda$ arrives at the receiver at times that differ by

$$\Delta t = D \Delta\lambda$$

- The resulting fluctuations in received power at the sampling times are called **mode partition noise** (MPN)
- For multimode fibers, both MPN and speckle noise can occur

Mode partition noise (MPN)

Partitioning of laser power between laser modes does not change the total transmitted power and does not cause additional noise at the laser output.

However, different laser modes travel at different velocities in the fiber.

As a result, power fluctuations between modes lead to MPN at the fiber output.

Before transmission
After 1km 50MMF

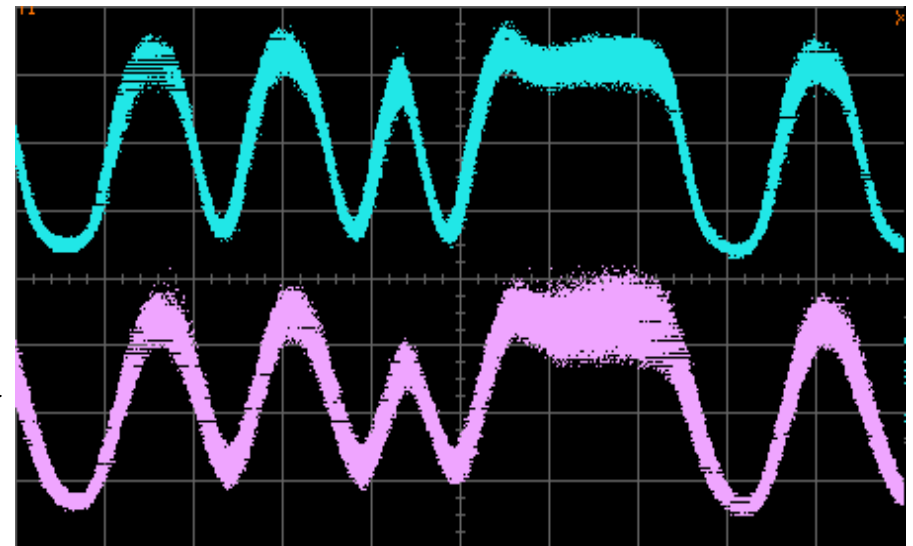

Mode partitioning example

Four optical spectra of the same device taken about 1 minute apart

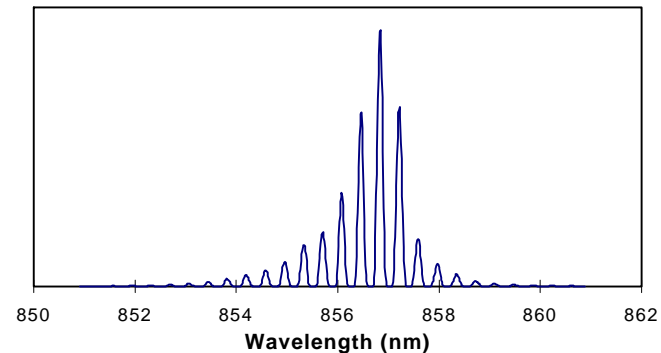
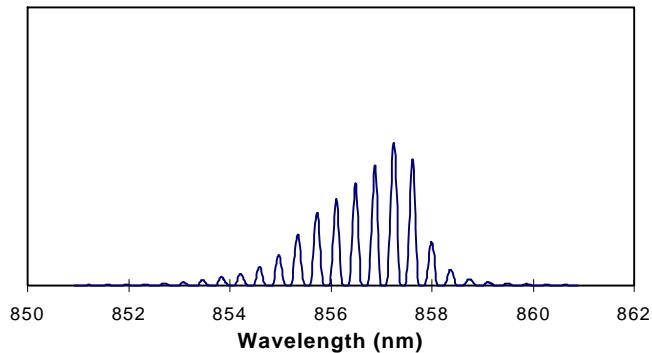
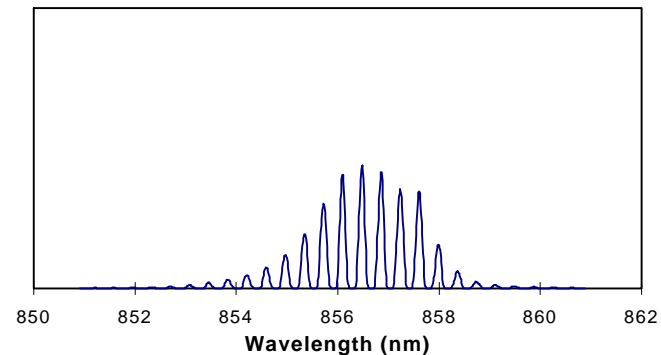
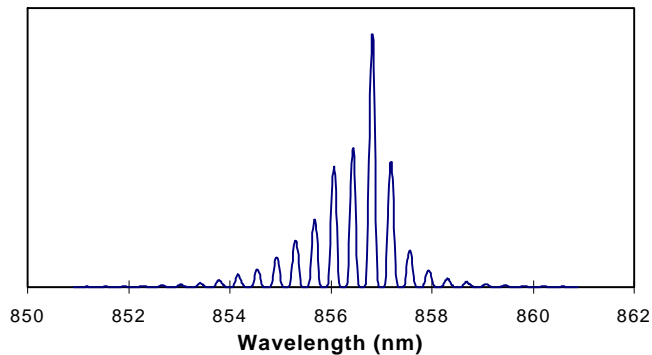

Note: These are time averaged measurements and do not give more than a qualitative indication that mode partitioning is happening.

Measuring Mode Partitioning

- need to isolate an individual laser mode and measure the statistics of the mode under modulation

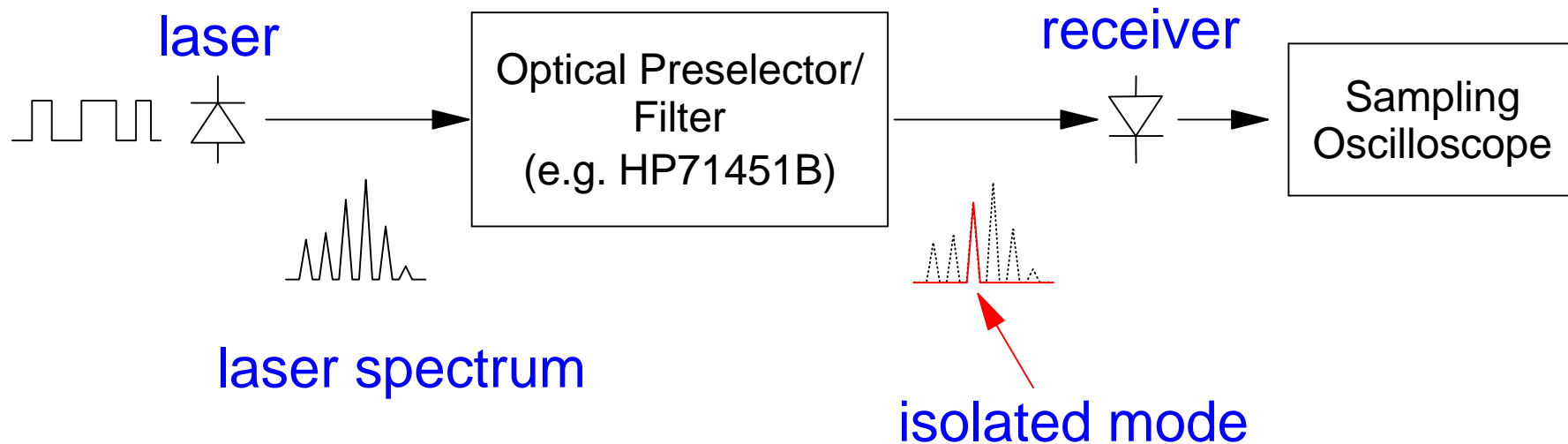

In the following results the laser was modulated at 1Gb/s and all scope traces had a scale of 2ns/div.

Mode partitioning - 790nm Fabry-Perot laser

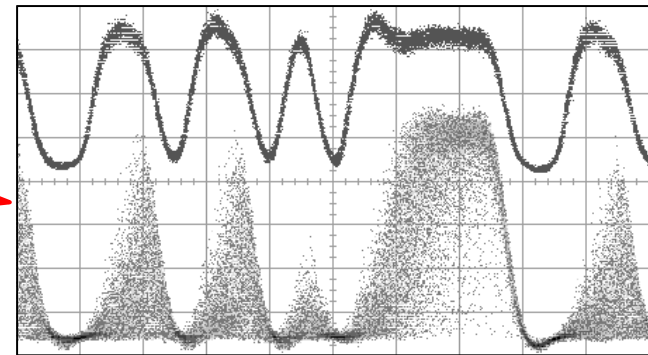
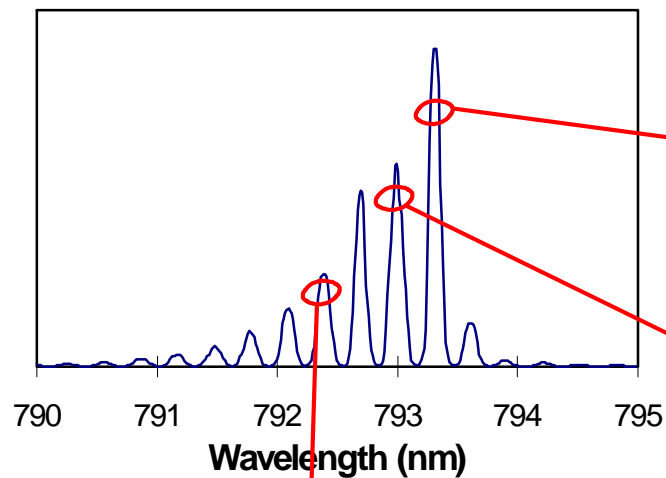

$\lambda=793.39\text{nm}$

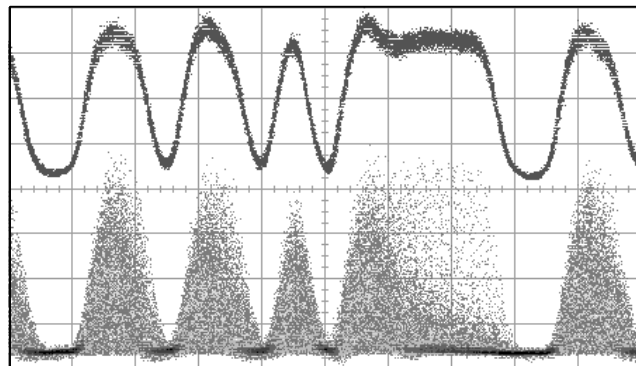

$\lambda=792.46\text{nm}$

← all modes →

← individual mode →

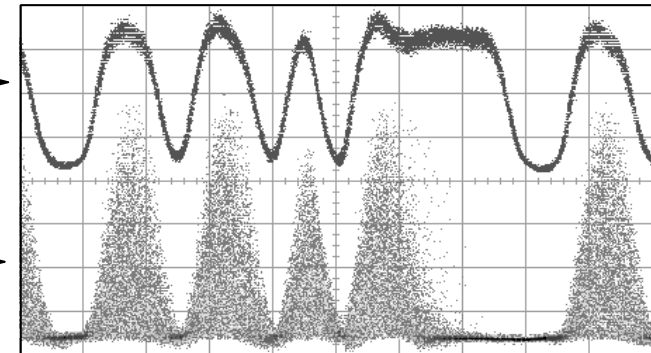

$\lambda=793.07\text{nm}$

Mode partitioning - 1300nm Fabry-Perot laser

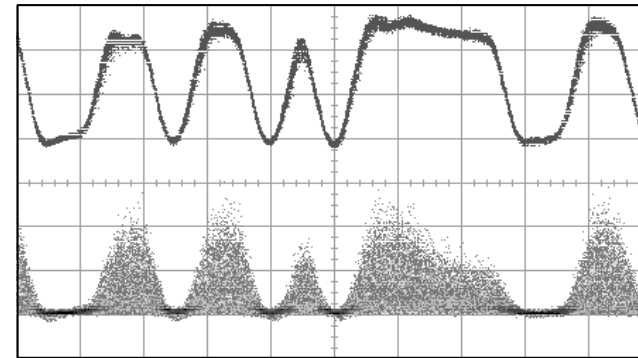
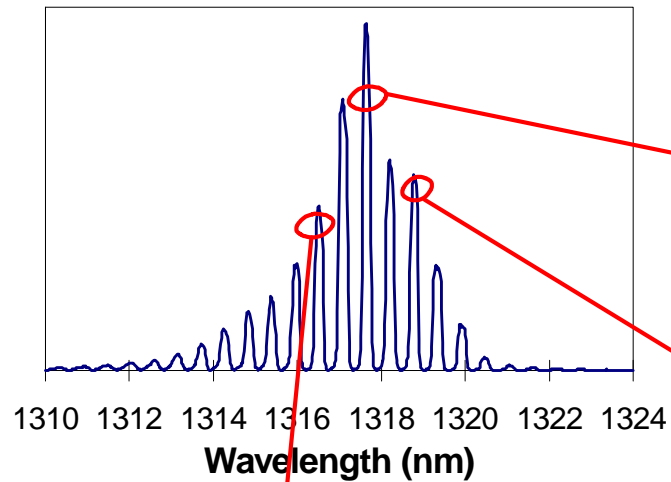

$\lambda=1317.6$

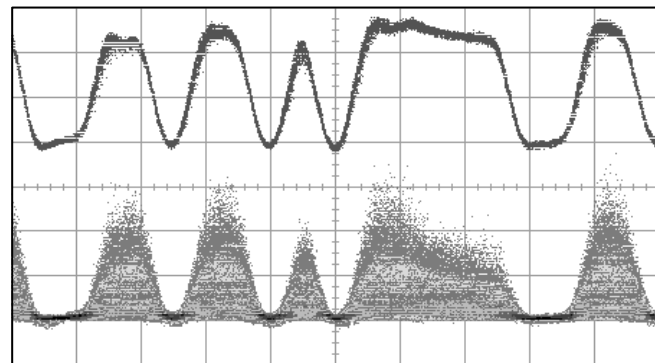

$\lambda=1316.48$

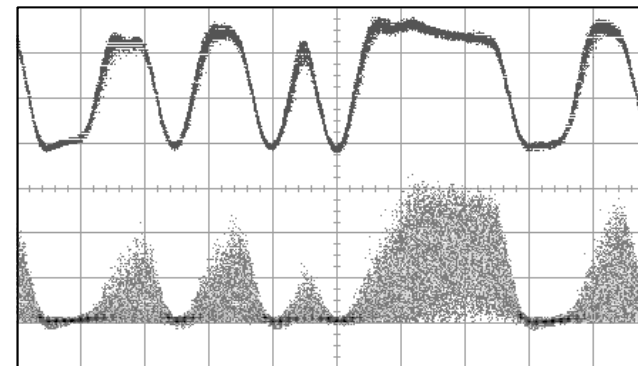

$\lambda=1318.76$

Mode partitioning - 850nm Fabry-Perot laser

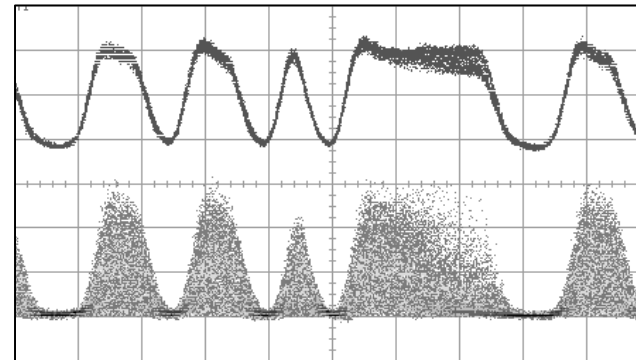
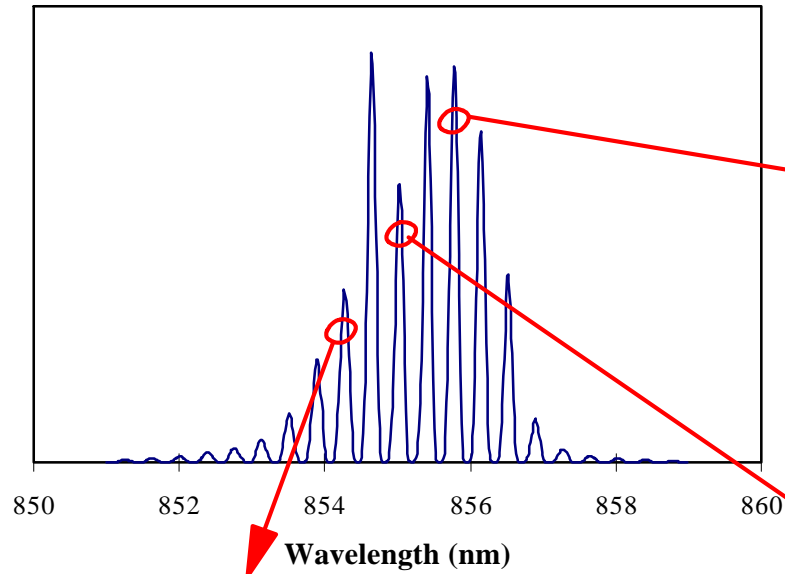

$\lambda=855.79\text{nm}$

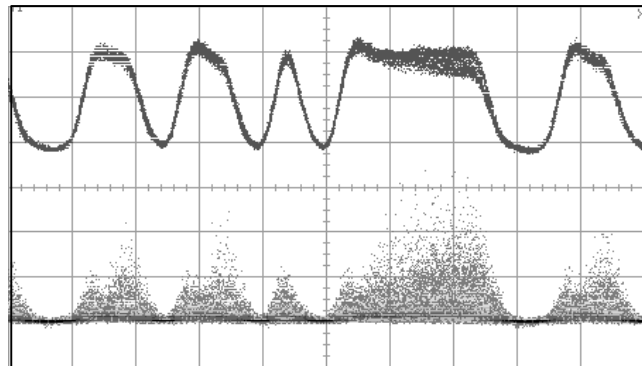

$\lambda=854.28\text{nm}$

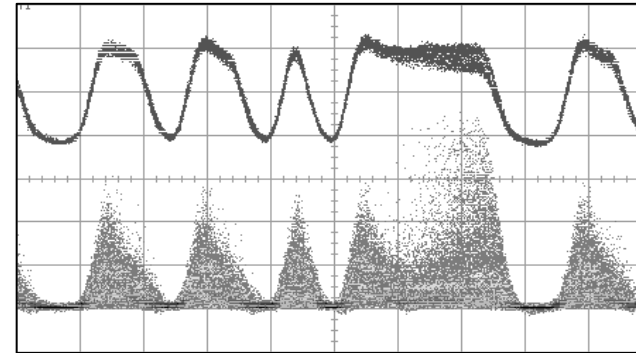

$\lambda=855.04\text{nm}$

MODAL BANDWIDTH OF MULTIMODE FIBER

- Overfilled launch: Excitation of a fiber with an optical source that launches all allowed ray angles over the end surface of the core
 - ▷ Usually accomplished with a LED source
 - ▷ Excites all fiber modes within the source linewidth
- Radially overfilled launch: Excitation of a fiber with an optical source that launches all allowed ray angles through the center of the core
 - ▷ Usually accomplished with a focused laser source
 - ▷ Excites only fiber modes that correspond to axial and meridional rays
 - ▷ If a central defect is present in the core, an axial ray does not have the same optical path length as a meridional ray
 - Serious **DMD** effects can occur
 - Transmitted pulse shape may exhibit large jitter
 - Bandwidth much lower than can be obtained with overfilled launch

Figure 10.3

Eye Diagram for a 500 m Length of Fiber Exhibiting Severe DMD

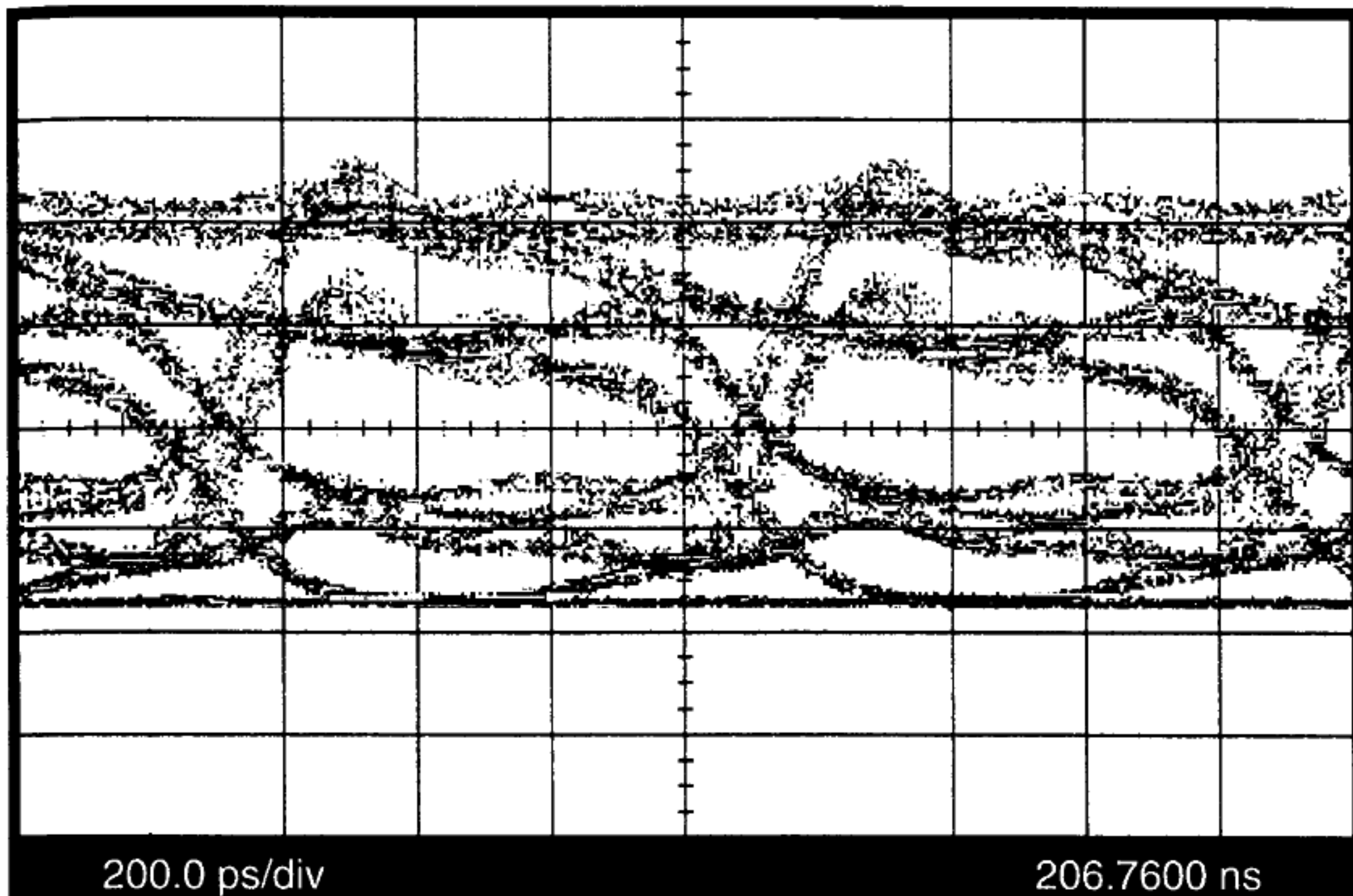

BANDWIDTH USAGE OF COMMUNICATION LINKS (1)

- Baseband

- ▷ Information is carried by a pulse train or an analog waveform
- ▷ Digital baseband is bit-serial or bit-group-serial
- ▷ Optimal when

$\text{spectral width of channel} \approx \text{spectral width of link}$

- ▷ Examples:

- RS-232, RS-422 over multiconductor cable
- Ethernet over 2- or 4-twisted pair cable or multimode optical fiber
- DS-1 transmission of multiplexed, digitized voice circuits over repeatered twisted-pair cable
- Long-haul, OC-12c or OC-48c data transmission over repeatered single-mode optical fiber

BASEBAND SPECTRUM

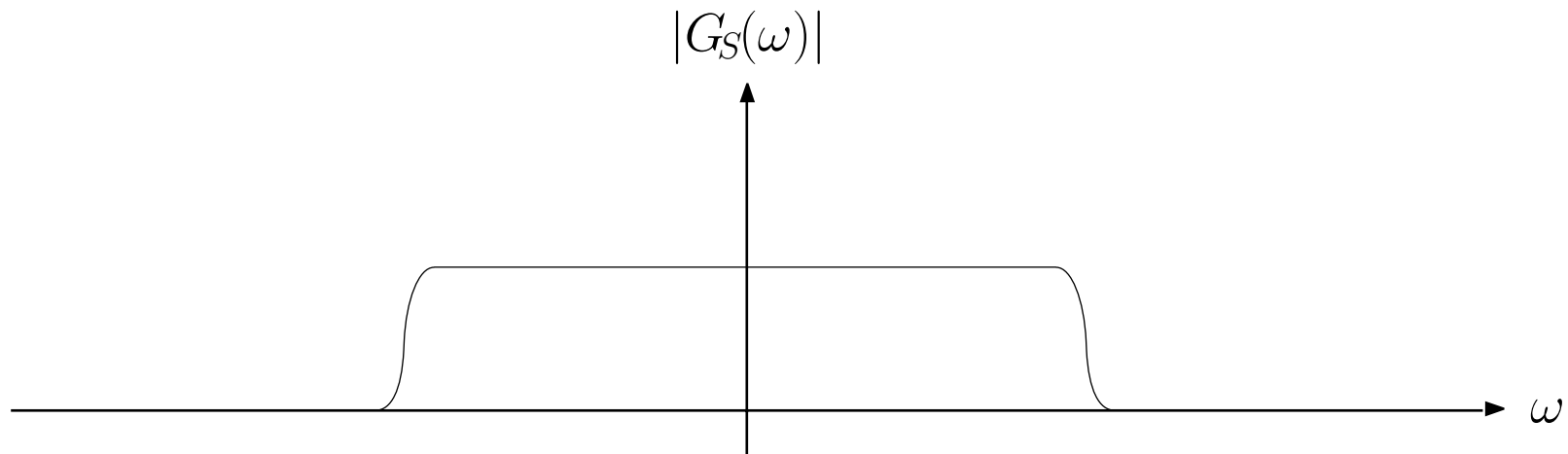

BANDWIDTH USAGE OF COMMUNICATION LINKS (2)

- Broadband (analog), passband (digital)
 - ▷ Multiple channels share the bandwidth of the link
 - ▷ Useful when
$$\text{spectral width of one channel} \ll \text{spectral width of link}$$
 - ▷ Examples:
 - Long-haul, OC-12c or OC-48c data transmission over repeatered single-mode optical fiber
 - ◇ A digital waveform is used to modulate an optical-frequency carrier
 - Wavelength division multiplexing (WDM) (\equiv optical FDMA)
 - ◇ Each channel has its own wavelength and bandwidth
 - Time division multiple access (TDMA)
 - ◇ Each channel is broadened to use the bandwidth of the link
 - ◇ Sharing of the channel occurs in signal space, not frequency space

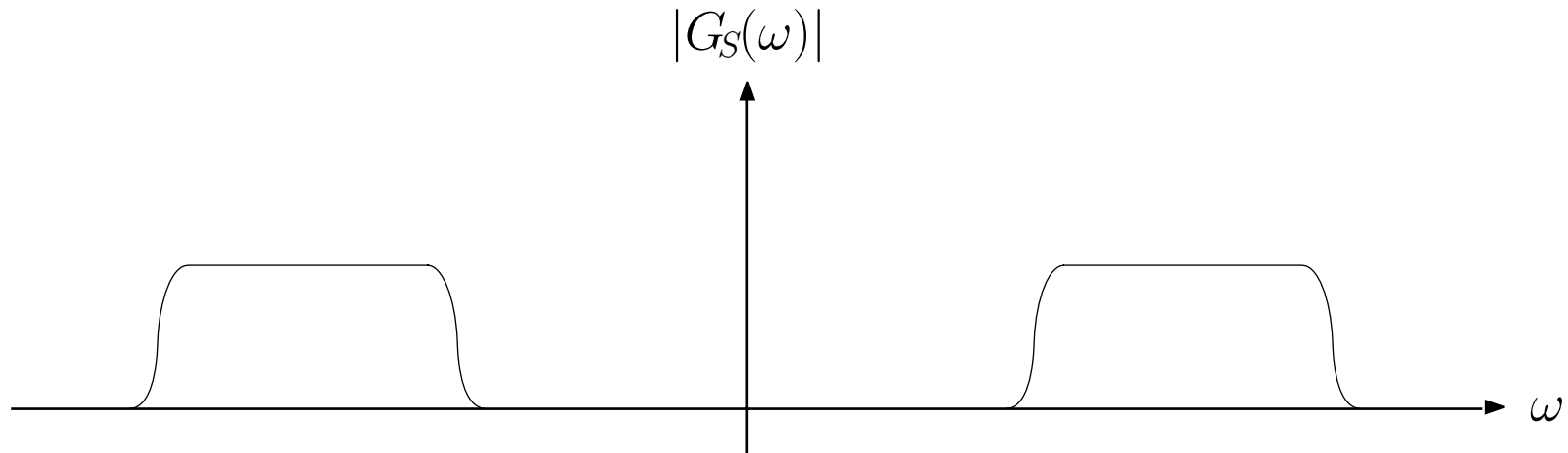
PASSBAND SPECTRUM (ONE CHANNEL)

- A real signal that is generated by modulating a carrier is a linear combination of positive and negative frequencies:

$$v(t) = |v_0(t)| \cos(\omega t + \phi(t)) = v_0(t)e^{j\omega t} + v_0(t)^*e^{-j\omega t}$$

- ▷ $v_0(t)$ is the complex envelope of the wave
 - Only $|v_0(t)|$ varies \Rightarrow amplitude modulation
 - Only $\phi(t)$ varies \Rightarrow phase (or frequency) modulation

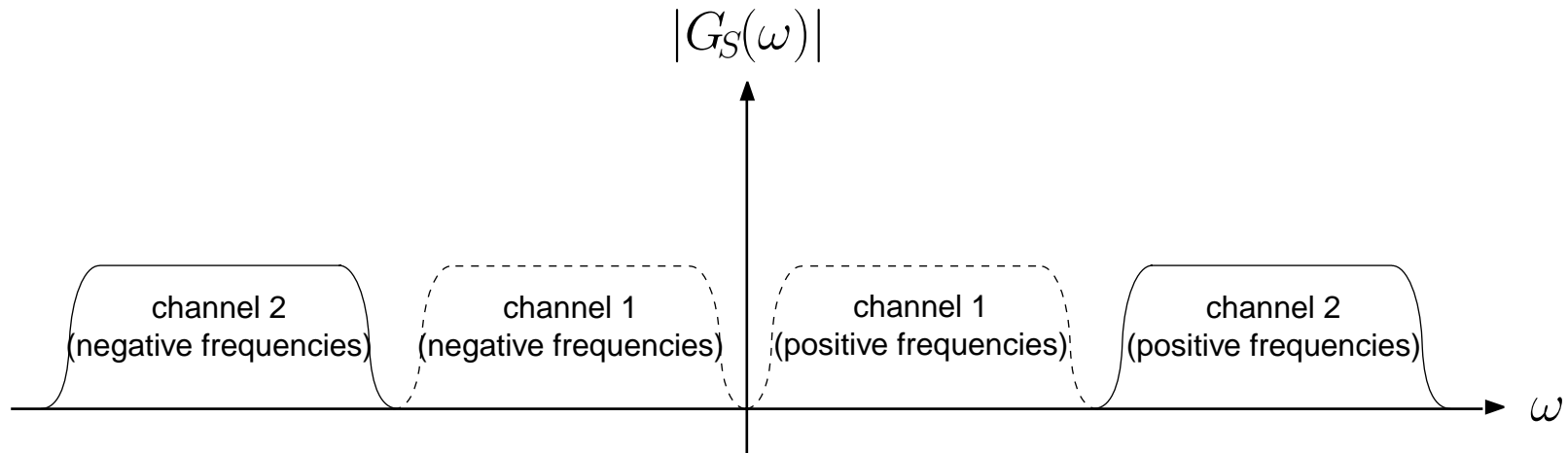
PASSBAND SPECTRUM (TWO CHANNELS)

- Two modulated cosine signals:

$$v(t) = |v_1(t)| \cos(\omega_1 t + \phi_1(t)) + |v_2(t)| \cos(\omega_2 t + \phi_2(t))$$

EXAMPLES OF BROADBAND TECHNOLOGIES

- Frequency division multiple access (FDMA) (RF)
 - ▷ Each channel has its own carrier frequency and bandwidth
 - ▷ Example 1: Broadcast cable TV network
 - Each broadcast channel has its own carrier frequency
Bandwidth is 6 MHz/channel
 - Example 2: Data/broadcast cable network
 - Each downlink data or broadcast channel has its own carrier frequency
in the range from 65 to 750 MHz; bandwidth is 6 MHz/channel
 - Each uplink data channel has a 768 kHz band in the range 5–42 MHz
- Wavelength division multiplexing (WDM) (\equiv optical FDMA)
 - ▷ Each channel has its own wavelength and bandwidth
- Time division multiple access (TDMA)
 - ▷ Each channel is broadened to use the bandwidth of the link
 - ▷ Sharing of the channel occurs in signal space, not frequency space

Concept of Frequency Division Multiplexing

Area is proportional to frequency bandwidth

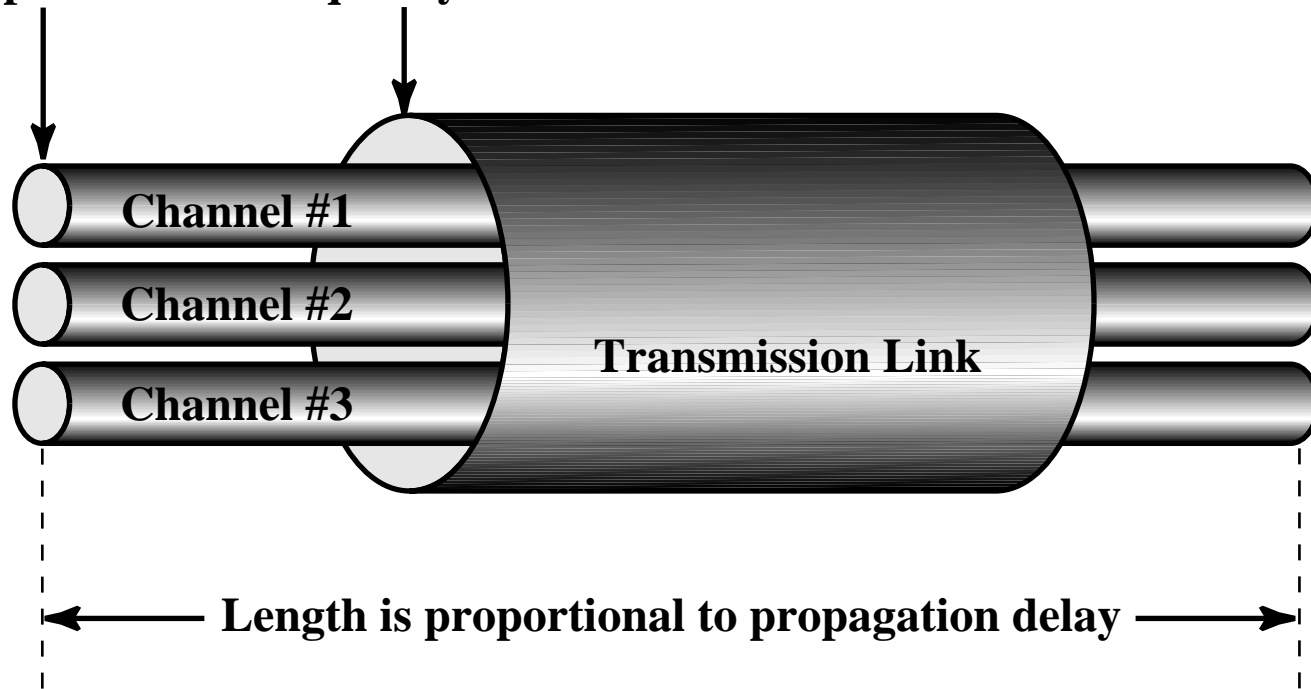

Wavelength Division Multiplexing (WDM)

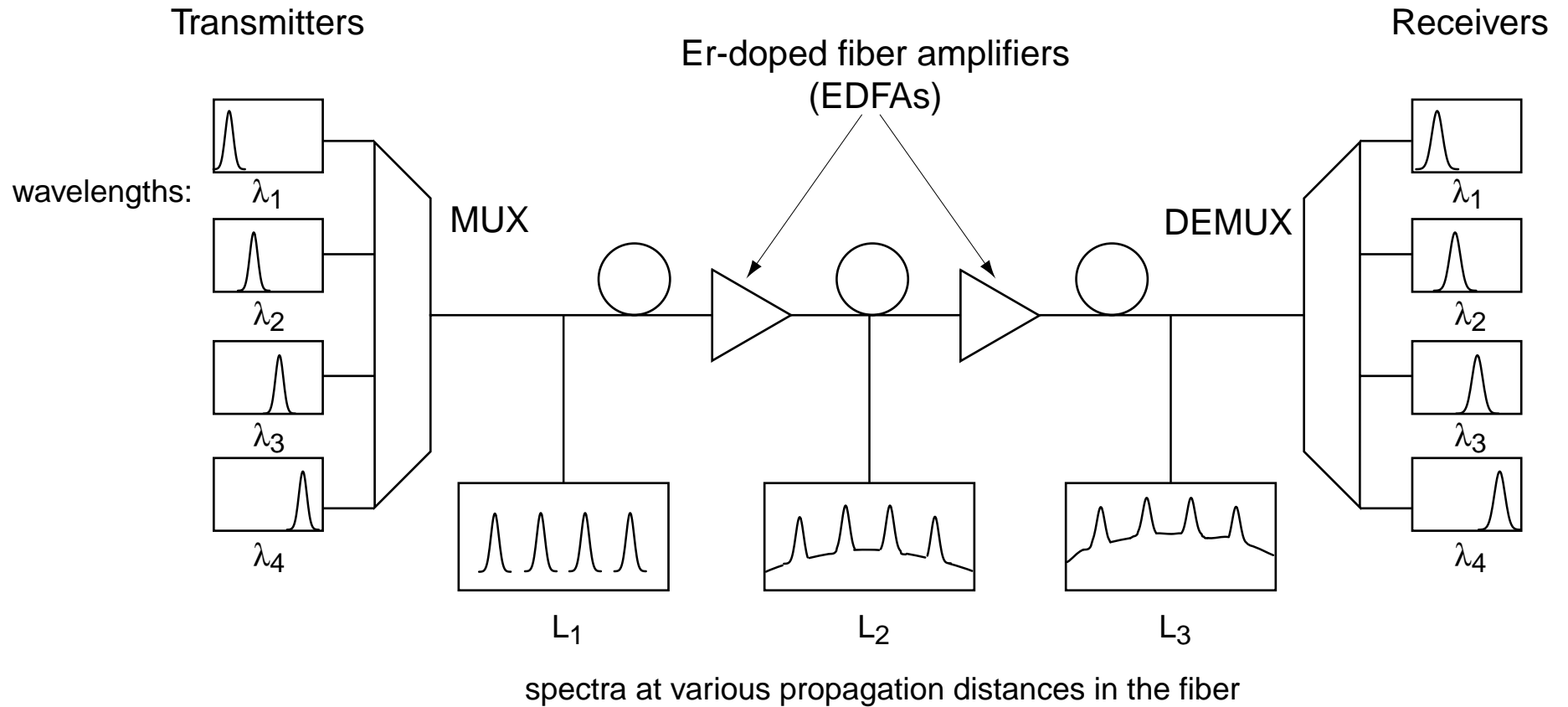

WHY WAS WDM LITTLE USED UP TO NOW?

- In second- and third-generation lightwave systems:
 - ▷ Laser bandwidth was high due to chirp
 - ▷ Lasers operated near 1310 nm to minimize dispersion in unshifted fiber, or near 1550 nm in dispersion-shifted fiber
 - ▷ Propagation distance was loss-limited up to $B \sim 1 \text{ Gb s}^{-1}$
 - ▷ Optical amplifiers were SCLA's (expensive)
 - ▷ Higher-bit-rate TDM was more cost-effective than WDM

WHY USE WAVELENGTH-DIVISION MULTIPLEXING?

- In fourth-generation lightwave systems:
 - ▷ Laser bandwidth is small
 - ▷ $B \gg 1 \text{ Gb s}^{-1}$ is possible
 - ▷ Lasers operate near 1550 nm to minimize loss
 - ▷ Zero-dispersion wavelength shifted from 1310 nm to near 1550 nm
 - ▷ Optical amplifiers are EDFA's (cheap)
 - ▷ Speed of electronic components is limited
 - ▷ Dispersion broadening near λ_0 depends on B^2

WHY *DIGITAL* COMMUNICATIONS?

- Digital encoding and decoding uses a finite **alphabet** of standard waveforms to represent bits or bit groups
- Digital techniques greatly reduce the effects of noise and distortion, and make it possible to approach theoretical information-capacity limits
 - ▷ Attenuation reduces the signal amplitude, but does not reduce the noise inserted by the channel in the same frequency band that the signal uses
 - ▷ Dispersion changes the waveform's shape in the course of propagation
- An analog system designer has very few means to disentangle the signal from the noise or the distortion
 - ▷ Remember long-distance calls carried on analog channels?
- Digital communication changes the paradigm from **waveform replication** to **waveform recognition**
 - ▷ Distortion and noise don't matter, as long as each digital waveform can be recognized and distinguished from a small set of other waveforms

A SINGLE-DUPLEX DIGITAL COMMUNICATION LINK

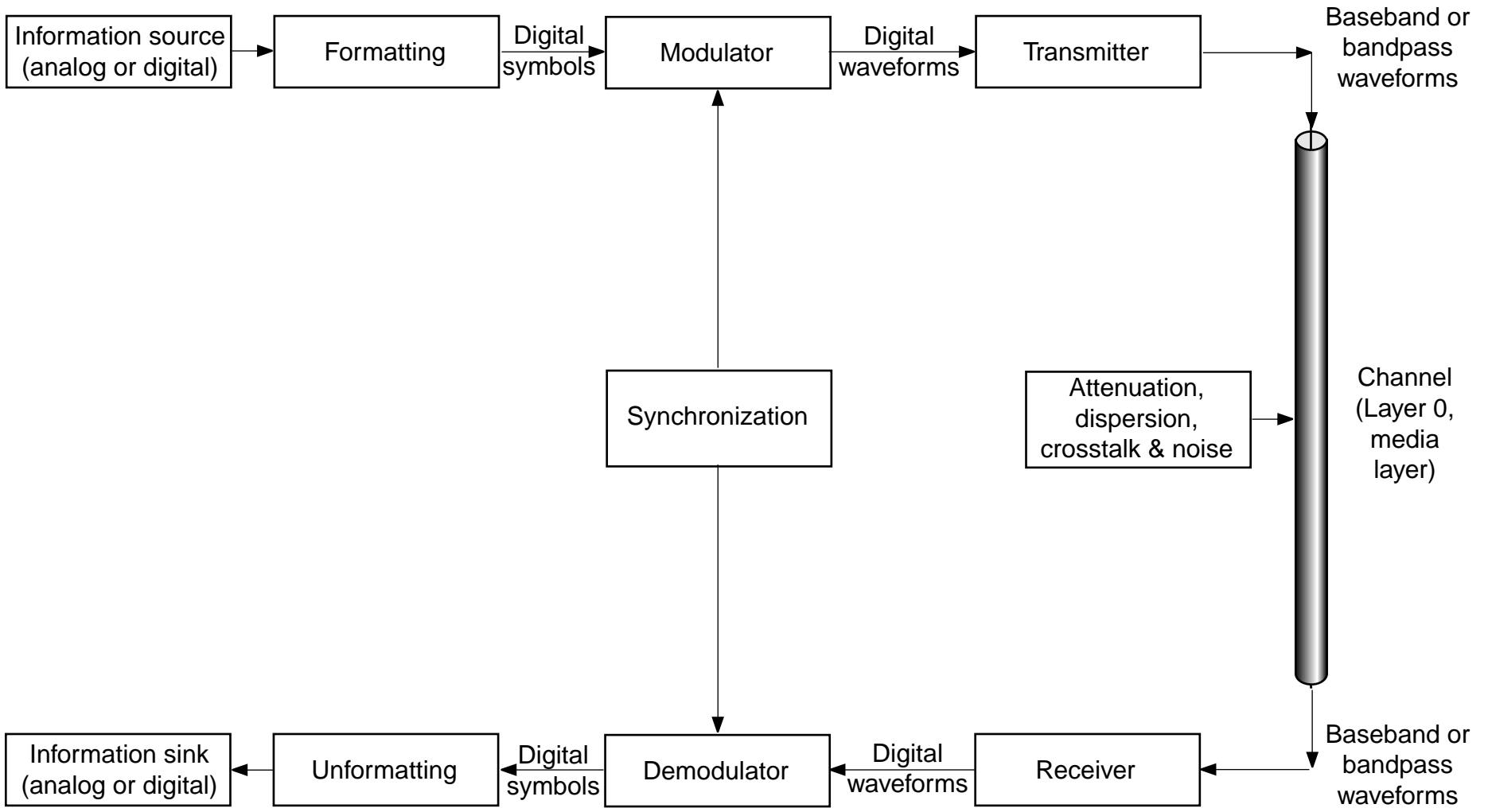

PHYSICAL EFFECTS ON DIGITAL WAVEFORMS

WAVEFORMS THAT REPRESENT THE BIT STREAM 101010...
AT THE BEGINNING AND END OF A SHORT CHANNEL

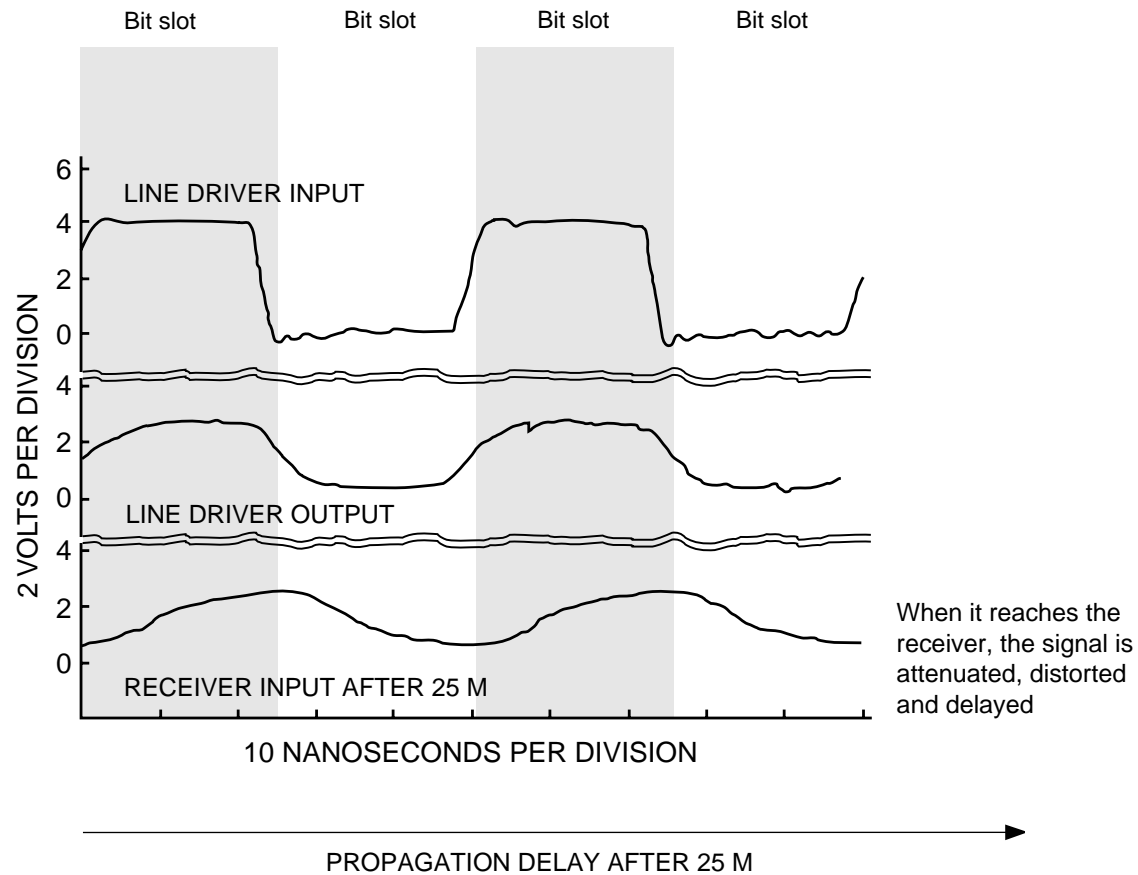

SYNCHRONIZATION IN DIGITAL COMMUNICATIONS

- The receiver needs to be able to identify each digital waveform that arrives, even in the presence of noise and distortion
 - ▷ If high voltage signals a “1” and low voltage signals a “0”, then one can identify the 1’s and 0’s by sampling at discrete times
 - ▷ If the sampling interval or phase are not correct, it is not possible to identify the received waveforms correctly
 - This leads to a **clock synchronization problem** \Rightarrow framing

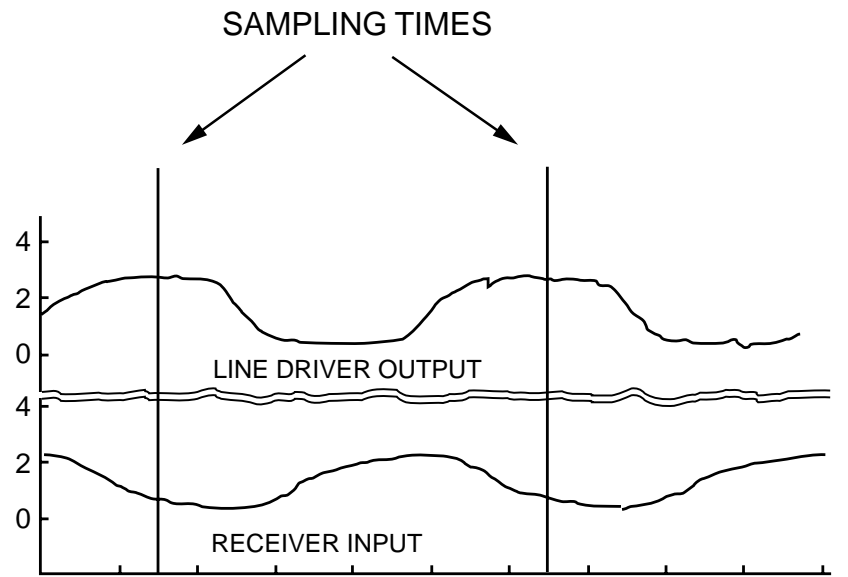

A FULL-DUPLEX DIGITAL COMMUNICATION LINK

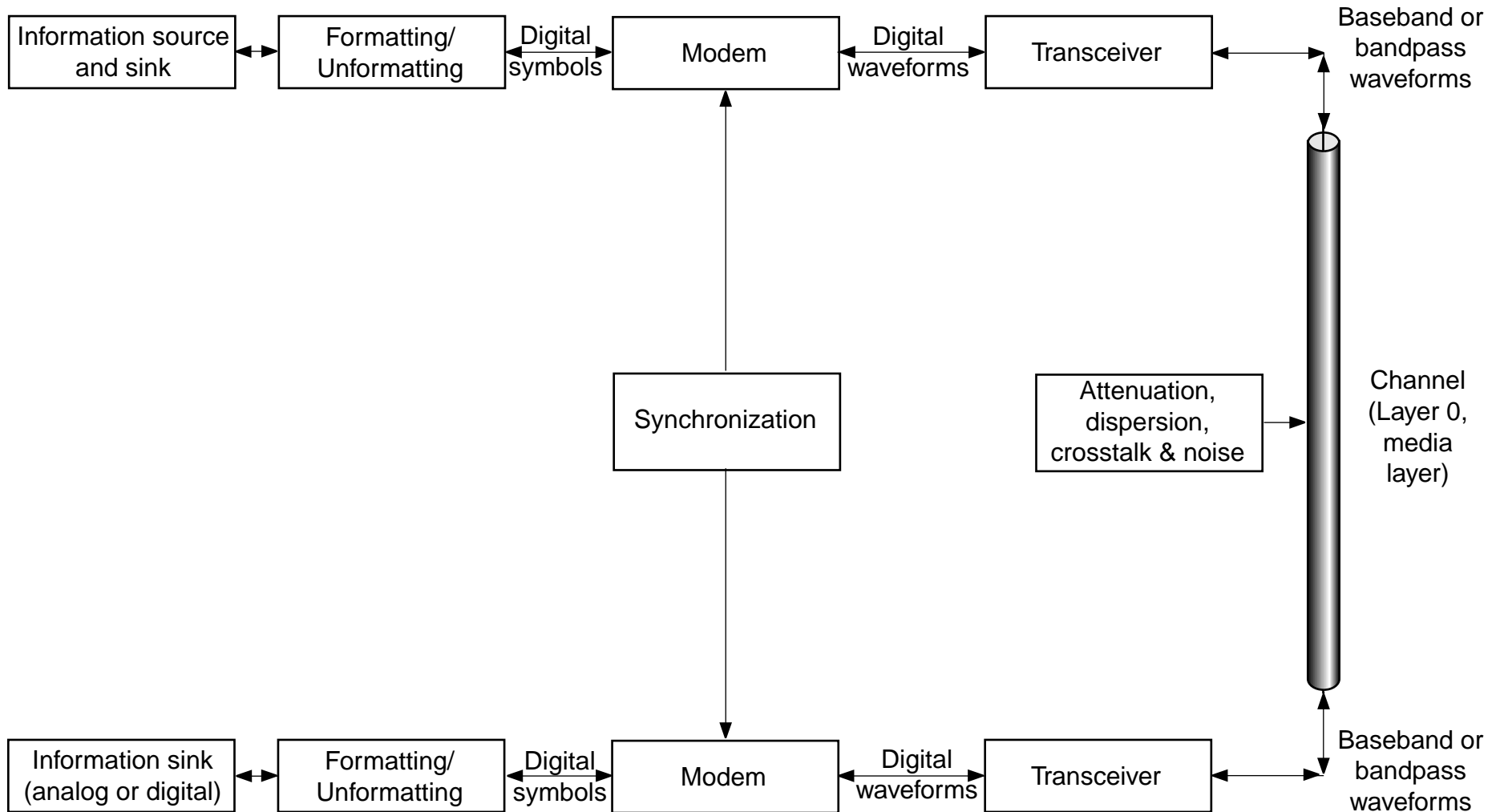

EYE PATTERNS (1)

- An **eye pattern** is obtained by superimposing the actual waveforms for large numbers of transmitted or received symbols
 - ▷ Perfect eye pattern for noise-free, bandwidth-limited transmission of an alphabet of two digital waveforms encoding a binary signal (1's and 0's):

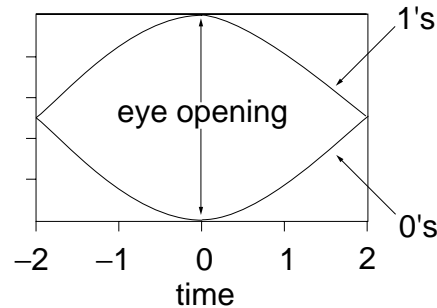

- ▷ Actual eye patterns are used to estimate the bit error rate and the signal-to-noise ratio

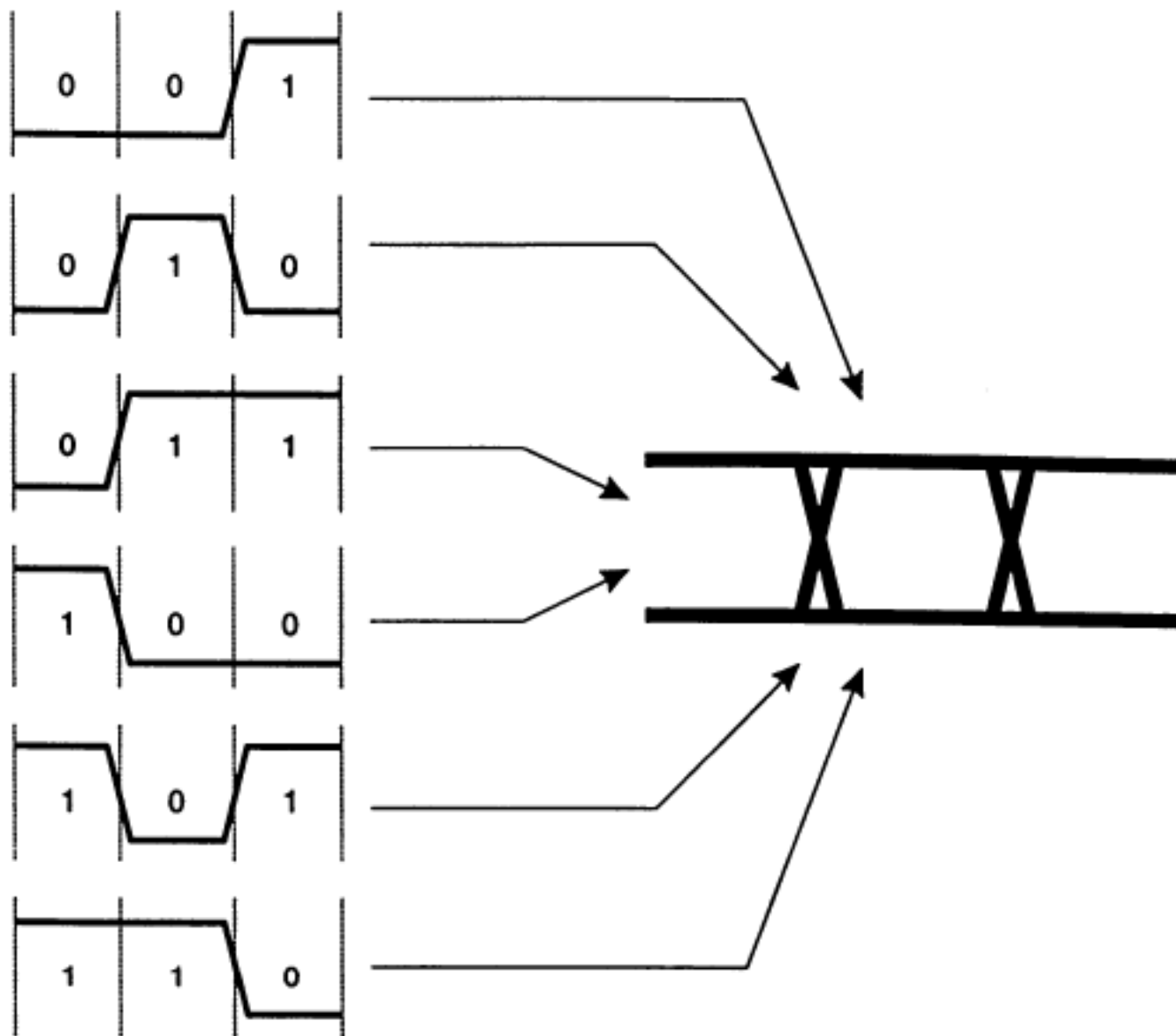

Figure 8.14 Concept of an eye diagram.

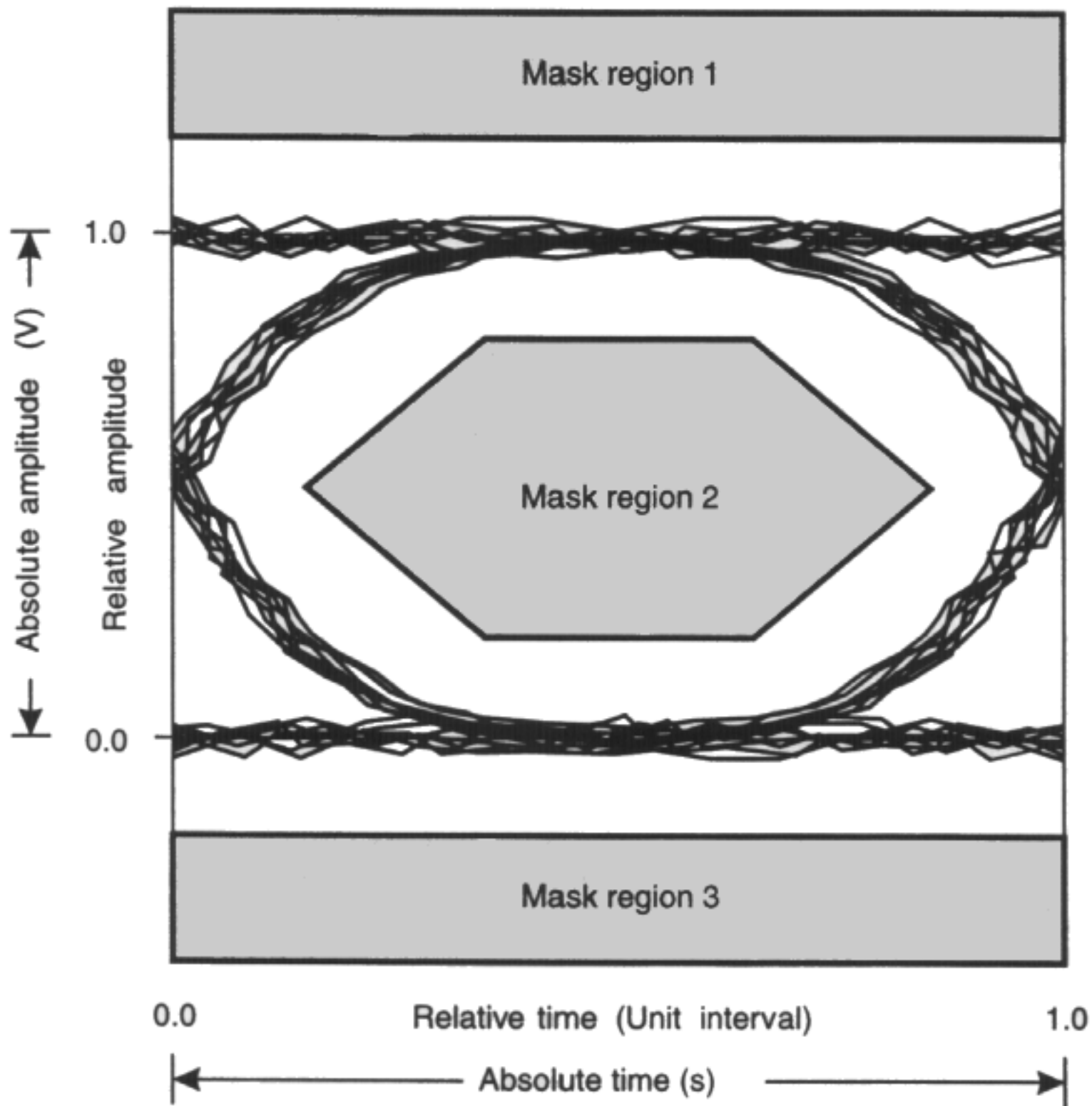
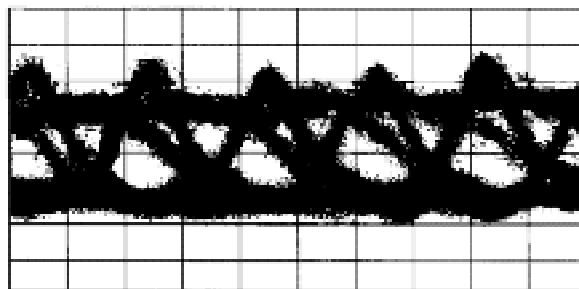
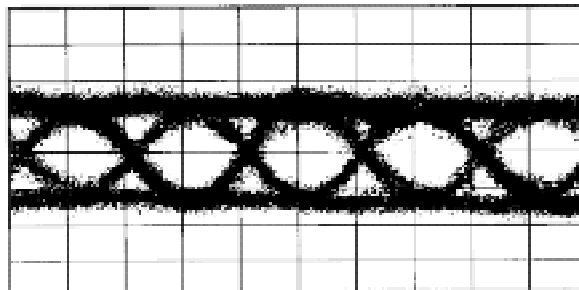

Figure 8.35 Concept of eye-diagram mask. Waveforms must not intrude into the shaded regions.

EYE PATTERNS (2)

- Observed eye patterns for fiberoptic transmission of a binary (two-level) ASK signal at $1.55 \mu\text{m}$ and 2.5 Gb/s . Horizontal scale: 200 ps/division .
Top: $L = 0 \text{ km}$; bottom: $L = 120 \text{ km}$.¹ Observed partial eye closing is due to self-phase modulation and group-velocity dispersion.



¹C. Y. Kuo et al., IEEE Photonics Technology Letters **2**, 911–913 (1990)

EYE PATTERNS (3)

- Eye pattern for 5-level PAM (PAM-5), as used to operate gigabit Ethernet over 4 unshielded twisted pairs:

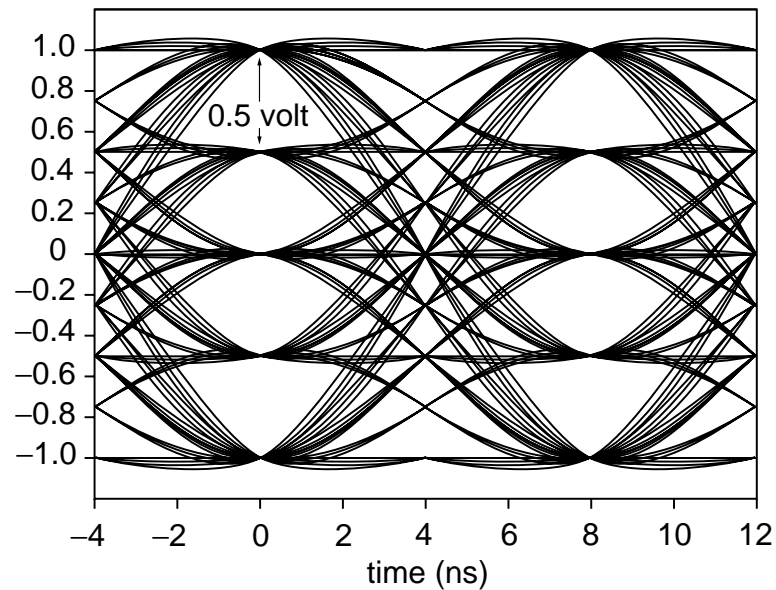

SOURCE CODING

● Code length:

▷ Let X be a discrete, memoryless source○ Alphabet is $\{x_1, \dots, x_m\}$; (probability of symbol x_i) = p_i

○ Average information content per symbol:

$$H(X) = - \sum_{i=1}^m p_i \log_2 p_i \quad \text{bits}$$

○ Beware! The bits used to represent numerical data are logically distinct from the bits used to represent information content

▷ Assign each symbol x_i a unique binary codeword of length n_i bits○ Average codeword length: $L = \sum_{i=1}^m p_i n_i$ bits● **Source coding theorem:**▷ Greatest lower bound on the average codeword length: $L \geq H(X)$ ▷ L can be made arbitrarily close to $H(X)$ by choice of codewords

CHANNEL CAPACITY

- Discrete, noise-free channel:

- ▷ Alphabet is $\{x_1, \dots, x_m\}$

- Assume that (probability of symbol x_i) = $1/m$ (\Rightarrow maximum entropy)

- Maximum channel capacity:

$$C = \frac{1}{T} \log_2 m \quad \text{bits/second}$$

- T = time to transmit one symbol (assumed to be the same for all)

- **Hartley-Shannon theorem** for a noisy channel:

- ▷ Assume white, band-limited, Gaussian noise

- ▷ Maximum channel capacity:

$$C = B \log_2 \left(1 + \frac{S}{N} \right) \quad \text{bits/second}$$

- ▷ B = channel bandwidth, S = signal power, N = noise power

BIT ERROR RATE (1)

- The bit error rate is the probability of detecting a bit incorrectly in amplitude-shift or on-off keying:

$$BER = p(1)P(0|1) + p(0)P(1|0)$$

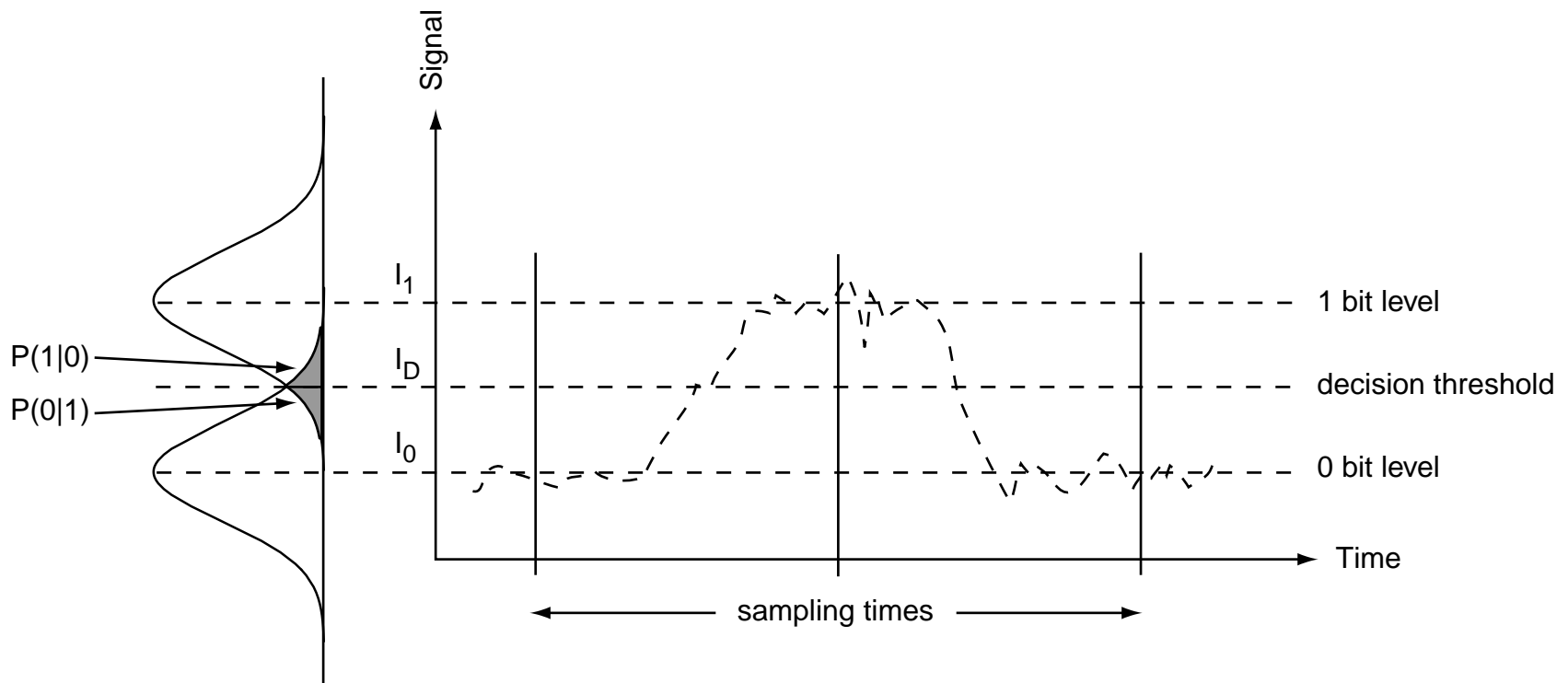

BIT ERROR RATE (2)

- Conditional probability:

$$P(0|1) = \frac{1}{\sigma_1 \sqrt{2\pi}} \int_{-\infty}^{I_D} \exp\left(-\frac{(I_1 - I)^2}{2\sigma_1^2}\right) dI = \frac{1}{2} \operatorname{erfc}\left(-\frac{I_1 - I_D}{\sigma_1 \sqrt{2}}\right)$$

$$\operatorname{erfc}(x) = \text{complementary error function} = \frac{2}{\sqrt{\pi}} \int_{-\infty}^x e^{-u^2} du$$

- ▷ Minimum BER occurs when the decision threshold is chosen such that

$$\frac{I_1 - I_D}{\sigma_1} = \frac{I_D - I_0}{\sigma_0}$$

- ▷ Define

$$Q = \frac{I_1 - I_0}{\sigma_1 + \sigma_0}$$

- ▷ At the optimum setting of I_D ,

$$\text{BER} = \frac{1}{2} \operatorname{erfc}\left(\frac{Q}{\sqrt{2}}\right) \approx \frac{e^{-Q^2/2}}{Q\sqrt{2\pi}}$$

DIGITAL TRANSMISSION OF ANALOG SIGNALS

- Example: North American PSTN
- The analog time-varying voltage produced by sound waves impinging on a microphone travels over a twisted pair of copper wires to an **end office**
 - ▷ The time-varying voltage is sampled at intervals of $125 \mu\text{s}$ (8000 s^{-1})
 - The result is a **pulse amplitude modulation** signal
 - Original baseband signal can be reconstructed from PAM sequence
 - Could transmit the PAM sequence on trunk lines, but then we'd have distortion and noise...
 - ▷ The PAM signal is **quantized** and **encoded** digitally using 8 bits/sample
 - The result is a **pulse code modulation** signal
 - Quantization noise is an unavoidable side effect of digitization
- The octets from 24 different logical channels are inserted into a **DS-1** frame and transmitted over a trunk line at a rate of 8000 frames/second

PULSE AMPLITUDE MODULATION (PAM)

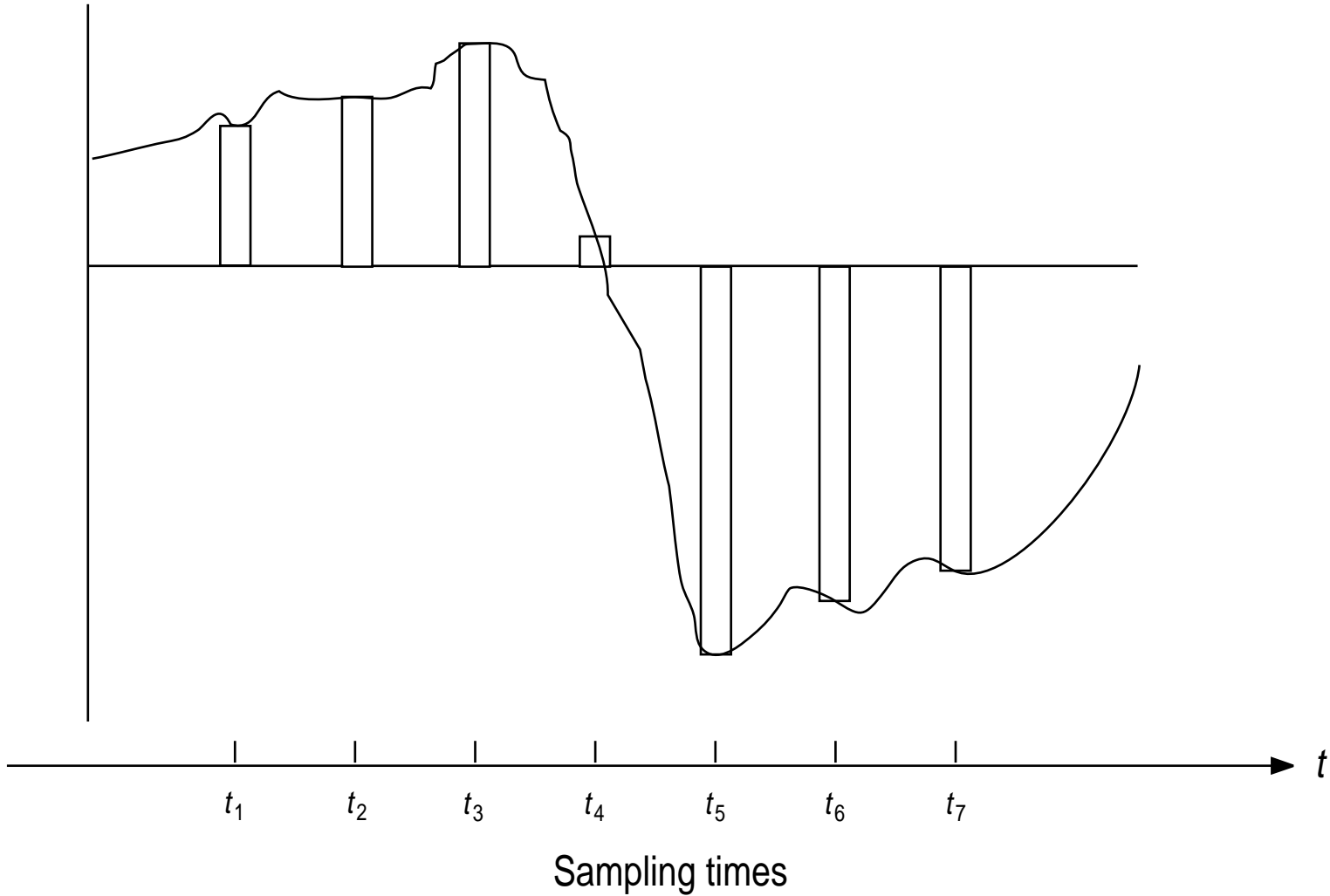

ANALOG TO DIGITAL CONVERSION

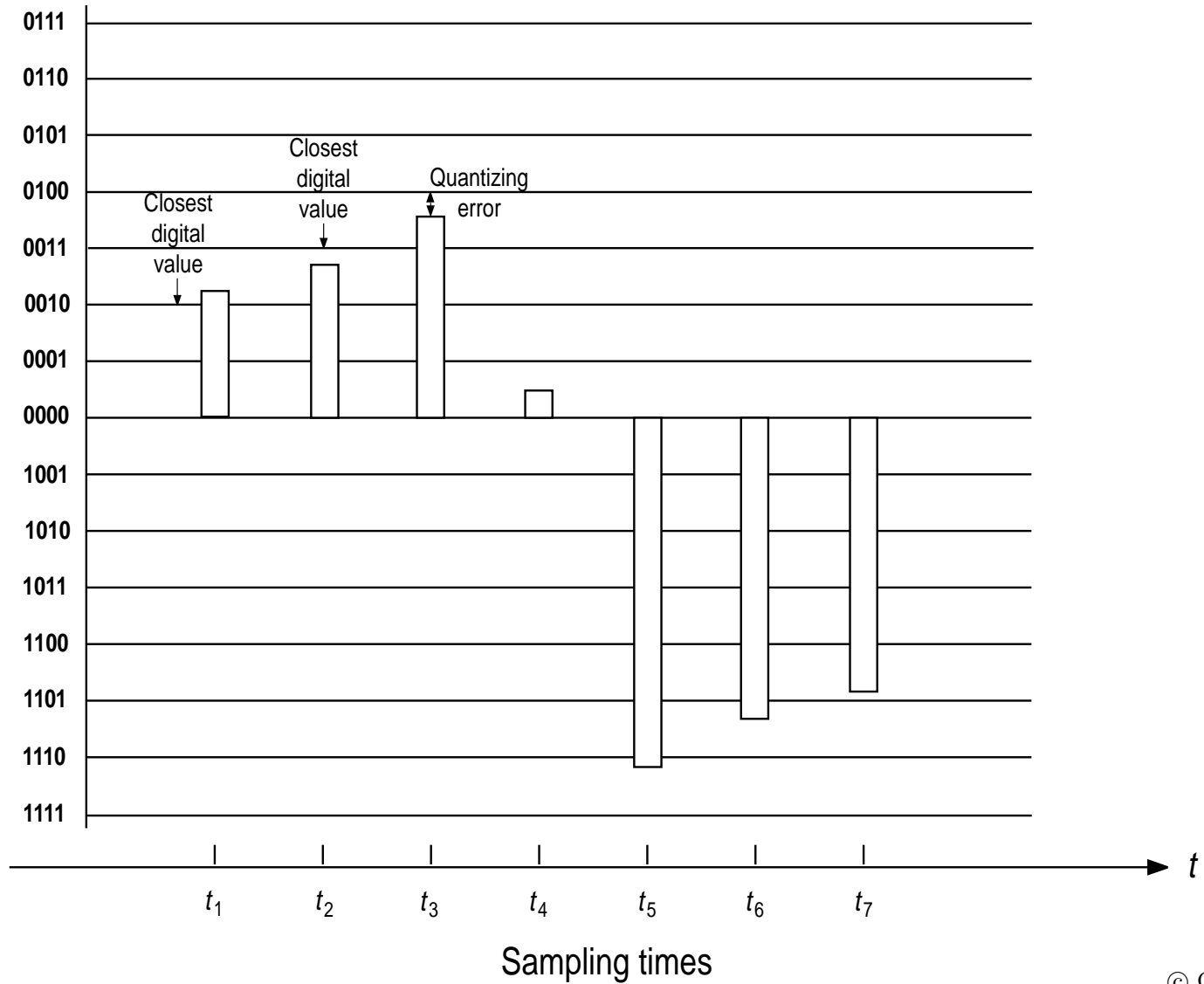

PULSE CODE MODULATION (PCM) CODING

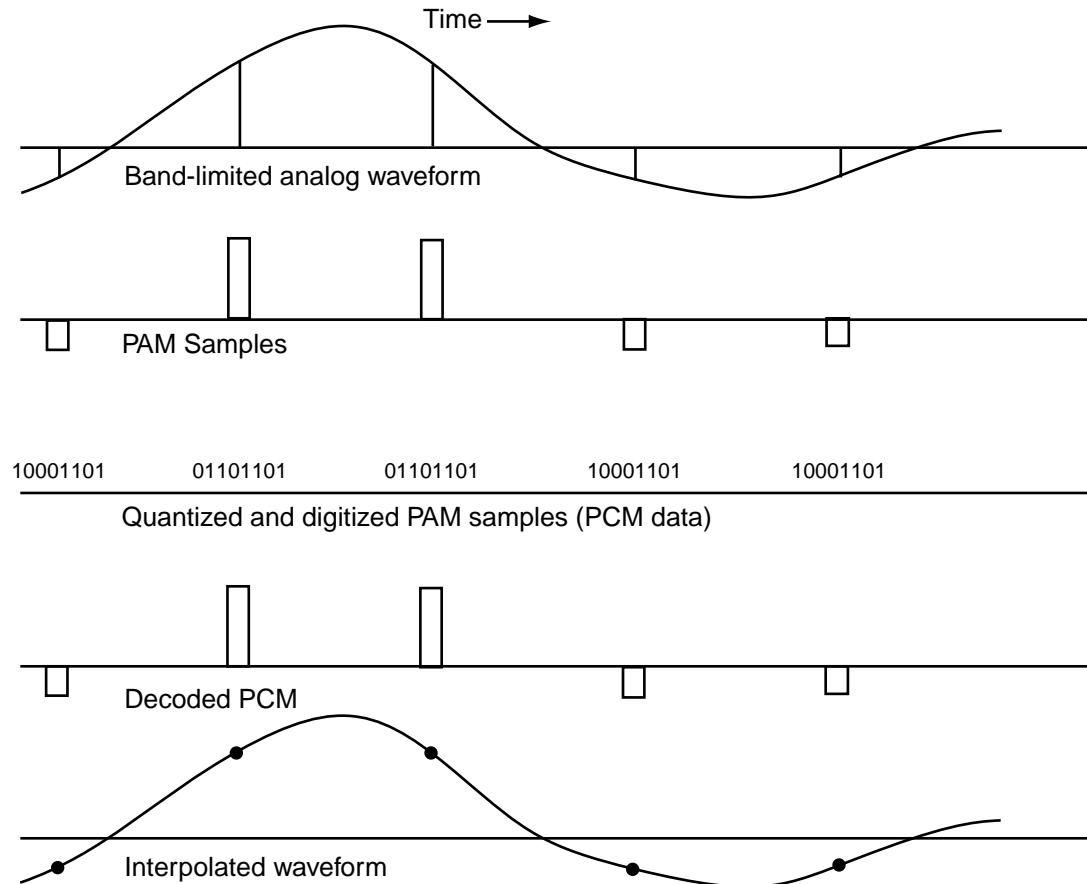

MU-LAW ENCODING

- Purpose: Map the (theoretically infinite) range of sound volumes onto a finite interval, after sampling the signal
 - ▷ Rationale: There are more low-amplitude than high-amplitude sounds in speech
 - ▷ There should be more quantization levels at low amplitudes than at high amplitudes
 - ▷ Quantization noise is an unavoidable side effect of digitization
- Mu-law equation:

$$v(f) = V \operatorname{sgn}(f) \frac{\ln \left[1 + \frac{\mu |f|}{V} \right]}{\ln(1 + \mu)}$$

- ▷ In North America, $\mu = 255$

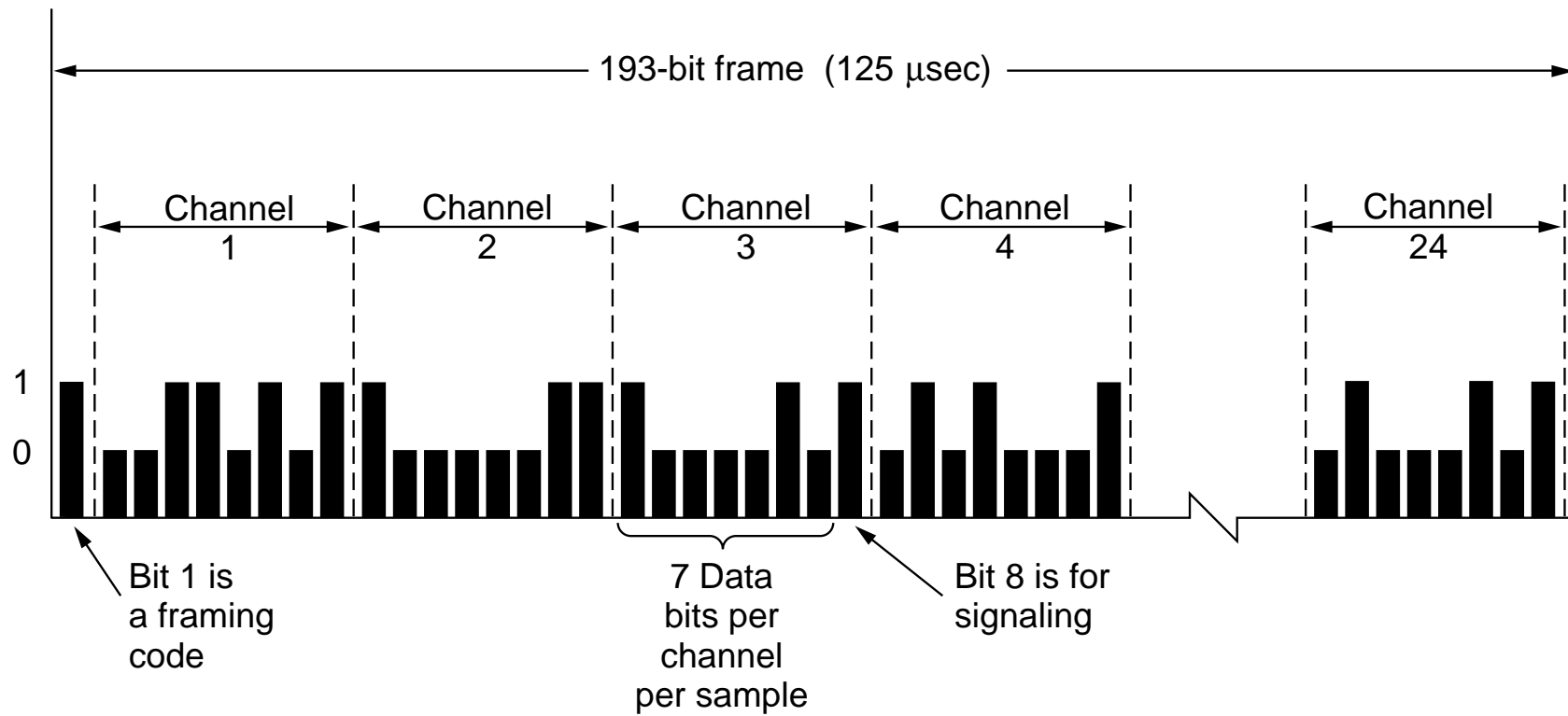

Time Division Multiplexing (TDM): DS-1 frame (1.544 Mb/s)

T-1 CHANNEL BANKS

- Purposes:
 - ▷ Transmitting: Convert 24 analog channels to 24 digital channels, and multiplex the digital channels into T-1 frames
 - ▷ Receiving: Demultiplex T-1 frames into 24 digital channels, and convert the digital channels to 24 analog channels
- Functions provided:
 - ▷ Multiplexing and demultiplexing
 - ▷ Handle signaling information for each channel
 - ▷ Generate/read framing bits

CHANNEL BANK (TRANSMITTING)

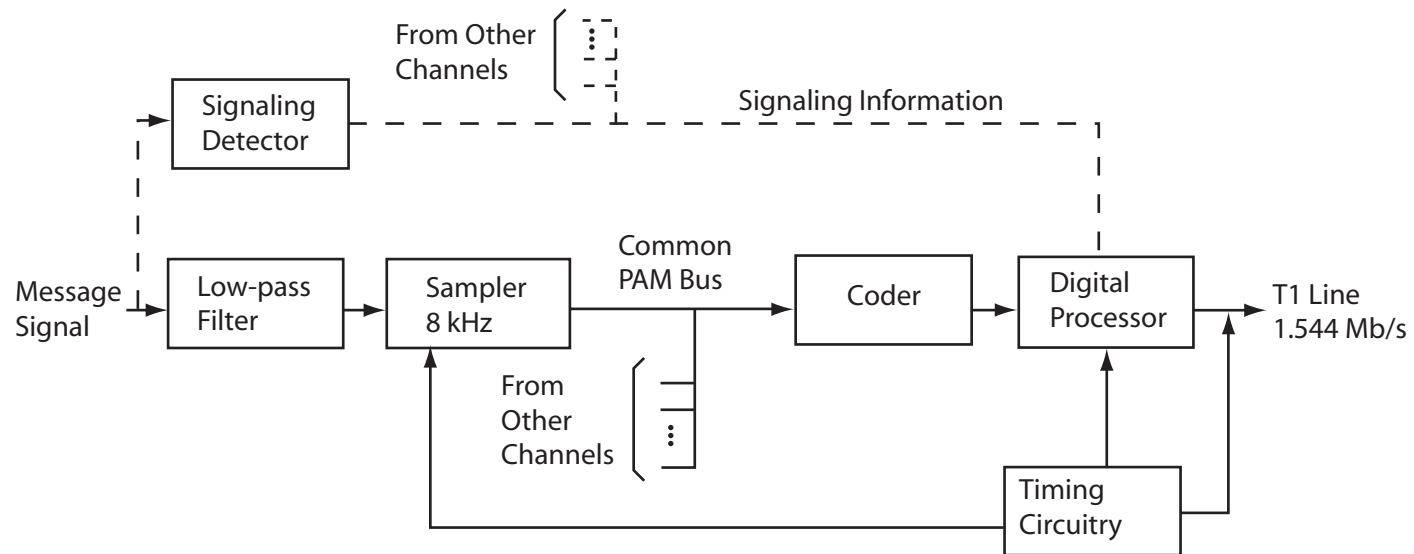

CHANNEL BANK (RECEIVING)

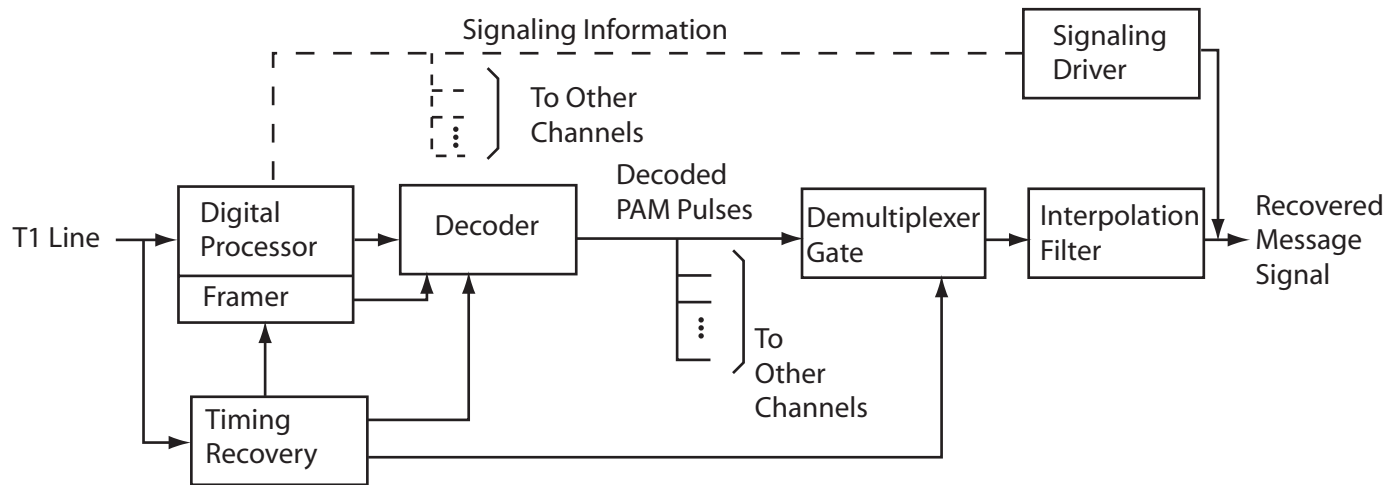

TDMA TECHNOLOGIES (1)

- Switching can be accomplished by interchanging time slots (**time-division switching**)
- Bit multiplexing
 - ▷ Each time slot contains 1 bit from each channel for that time slot
 - ▷ Requires synchronization
 - ▷ Switch fabric must be reconfigurable in 1 bit time
- Block multiplexing
 - ▷ Each time slot contains the block transmitted by one channel in one frame time
 - ▷ Requires synchronization
 - ▷ Switch fabric must be reconfigurable between frames

**TDM SIGNAL HIERARCHY
(NORTH AMERICA, JAPAN, KOREA)**

Designation	Channels	Data Rate (Mb/s)	Comments
DS-0	1	0.064	8 kHz × 8 bits PCM voice channel
DS-1	24	1.544	T-1 1 timing bit/frame
DS-1c	48	3.152	T-1c
DS-2	96	6.312	T-2
DS-3	672	44.736	T-3
DS-4	4032	274.176	T-4

TDM SIGNAL HIERARCHY (EUROPE — ITU)

Designation	Channels	Data Rate (Mb/s)
E1	30	2.048
E2	120	8.448
E3	480	34.368
E4	1920	139.264
E5	7680	565.148

SONET/SDH SIGNAL HIERARCHY

SONET Designation	ITU-T Designation	Data Rate (Mb/s)	Payload Rate (Mb/s)
STS-1/OC-1		51.84	50.112
STS-3/OC-3	STM-1	155.52	150.336
STS-9/OC-9	STM-3	466.56	451.008
STS-12/OC-12	STM-4	622.08	601.344
STS-18/OC-18	STM-6	933.12	902.016
STS-24/OC-24	STM-8	1244.16	1202.688
STS-36/OC-36	STM-12	1866.24	1804.032
STS-48/OC-48	STM-16	2488.32	2405.376
STS-192/OC-192	STM-64	9953.28	9621.504

TDMA TECHNOLOGIES (2)

- Code division multiple access (CDMA)
 - ▷ Each channel transmits bits using a unique code
 - The code is a sequence of short pulses (chips)
 - Must be orthogonal to the codes of all other channels
 - ▷ Extensively used in wireless communications
- Packet switching
 - ▷ Bit rate for each channel is set at the link's maximum value
 - ▷ Each channel transmits when the link becomes available
 - ▷ Each channel transmits information in “chunks”, or **packets**
 - ▷ Addressing information is carried in a **header** in each packet
 - ▷ Switch fabric (if used) must be reconfigurable in the time of a minimum-length packet
 - ▷ Contrast a bandwidth-limited link with a transmission-time-limited link (see next slide)

A bandwidth-limited link

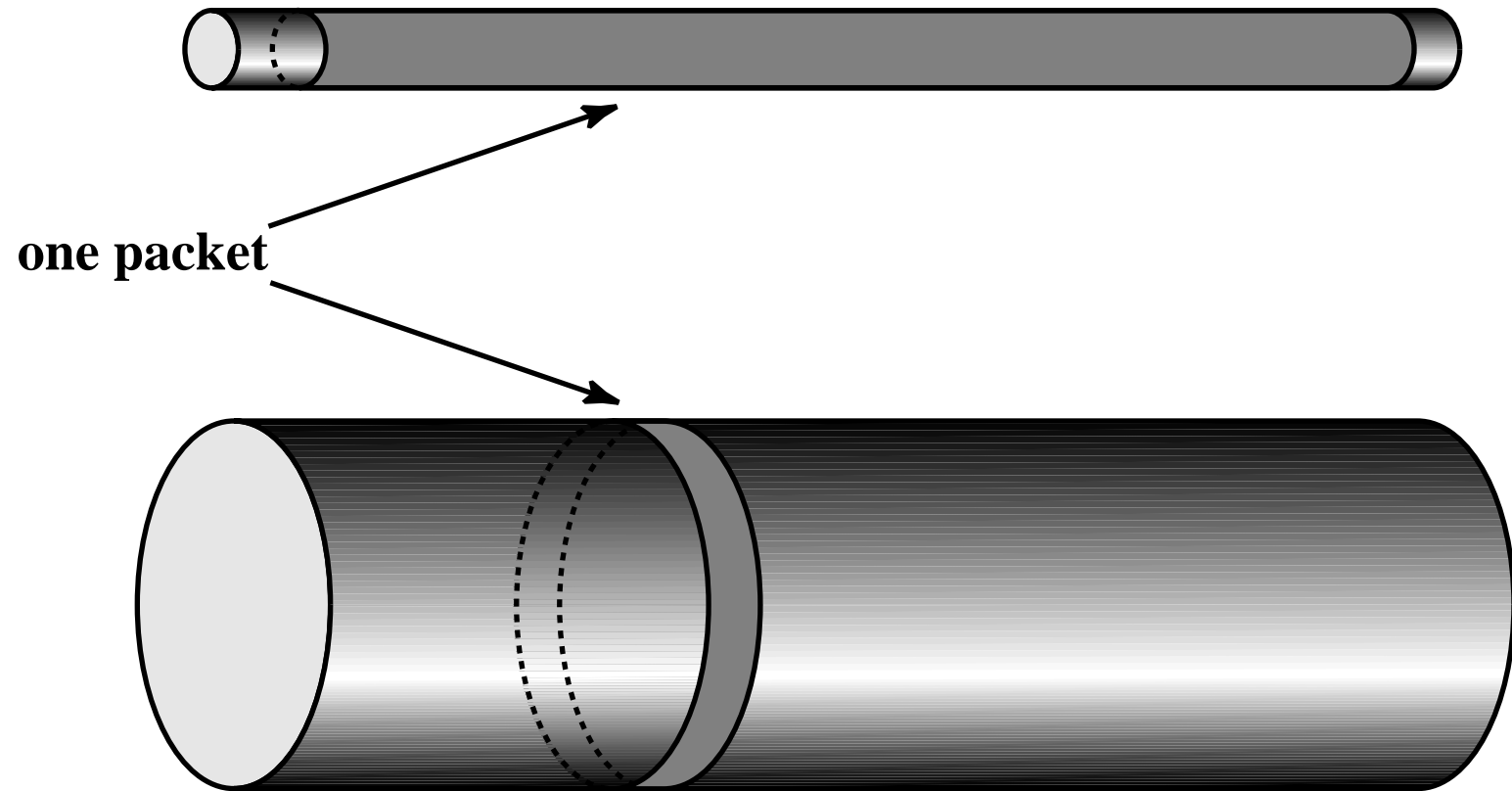

A transmission-time-limited link

HOW PROPERTIES OF PHYSICAL LINKS AFFECT NETWORK ARCHITECTURE (1)

- Important properties of physical links include:
 - ▷ How adequate bandwidth is achieved
 - ▷ Delay
 - ▷ Bit error rate
 - ▷ Need for synchronization
 - ▷ Whether physical channels are optical or electrical

HOW PROPERTIES OF PHYSICAL LINKS AFFECT NETWORK ARCHITECTURE (2)

- How is **adequate bandwidth** achieved?
 - ▷ Bit-parallel transmission (as in a bus) is usually not an option
 - Bus skew
 - ◇ Because pulses traveling on different wires in a multiwire cable experience slightly different electromagnetic environments, the pulses on different wires don't all arrive at the same time
 - ◇ Makes long-distance, bit-parallel communications *very* difficult
 - ▷ Usable bandwidth depends on distance
 - Copper cable: Attenuation depends on transmission distance (skin effect)
 - Optical fiber: Excessive values of (group velocity dispersion) \times distance \times (bandwidth of pulse in wavelength) lead to intersymbol interference
 - ▷ The usual solution for limited bandwidth is multiple channels (synchronized: TDM; non-synchronized: FDM, WDM)

HOW PROPERTIES OF PHYSICAL LINKS AFFECT NETWORK ARCHITECTURE (3)

• Delay

- ▷ Subject to an upper bound for real-time applications (especially voice)
- ▷ Electromagnetic propagation delay = distance/ v_g
 - For optical fiber, $v_g \approx \frac{2}{3}c = 2 \times 10^8$ m/s
 - ◇ 200 meters: propagation delay $\approx 1 \mu\text{s}$ (LANs)
 - ◇ 200 kilometers: propagation delay ≈ 1 ms (MANs, small WANs)
 - ◇ 20,000 kilometers: propagation delay ≈ 0.1 s (planetary WAN)
- ▷ Buffer delay = (no. of bits buffered)/(bit rate)
- ▷ Routing, switching or regeneration delay
- ▷ Software or firmware delay (codecs, etc.)
- ▷ Measurements of delay:
 - Propagation delay: Time-domain reflectometry
 - Total delay: Software (e.g., **ping**, **traceroute**)

HOW PROPERTIES OF PHYSICAL LINKS AFFECT NETWORK ARCHITECTURE (4)

- **Bandwidth-delay product (BWD) and bit error rate**
 - ▷ BWD = volume of the pipe that represents a physical channel
 - BWD = no. of bits or bytes “in flight”
 - ◇ “In flight” means sent, but not yet received or acknowledged
 - ◇ BWD should be $\ll 1/\text{BER}$ (otherwise, too many retransmissions)
 - ◇ Fiberoptic transmission: $10 \text{ Gb/s} \times 1 \text{ s} = 10^{10} \ll 10^{12} = 1/\text{BER}$
 - ▷ BWD is an extremely important parameter for TCP

HOW PROPERTIES OF PHYSICAL LINKS AFFECT NETWORK ARCHITECTURE (5)

- **Synchronization** is necessary for bit-serial operation
 - ▷ Bit-serial digital signals can be decoded correctly only if the receiver uses a properly synchronized local clock
 - ▷ Synchronous communications: All clocks are hierarchically locked to a master clock (as in SONET)
 - ▷ Asynchronous communications: Clocking information is derived from the data transmitted (as in Ethernet or ATM)
 - ▷ Nearly all digital communication links longer than a few meters use **framed** blocks of bits or bit groups
 - Connection-oriented datalink layer: T-1 frame (24 8-bit samples)
 - Connectionless datalink layer: Ethernet frame

HOW PROPERTIES OF PHYSICAL LINKS AFFECT NETWORK ARCHITECTURE (6)

- **Electrical vs. optical channels**

- ▷ Electrons interact strongly with one another
 - They are good for switching, but not so good for transmission
 - Examples: The transistor, lossy transmission lines
- ▷ Photons interact very weakly with one another
 - They are good for transmission, but not for switching
 - Transmission example: Optical fiber
 - There's no optical transistor; therefore, most optical switching systems are optoelectronic (electrical control, optical datapath)
 - It's hard to make a fast WDM switch (incoming interface to outgoing interface *and* λ_1 to λ_2)
 - ◇ This “technical detail” influences the practicality of switched optical networks

SCALE vs. TYPE OF INTERCONNECTION

Interprocessor distance	Processors are located in the same	Interconnection topology	Examples (non-exclusive)
0.01 m	Die	bit-parallel bus	IC with CPU + FPU
0.1 m	PC board	bit-parallel bus	Processor daughtercard
1 m	System	bit-parallel bus	Multi-headed computer
10 m	Room or small building	bit-serial bus or ring; multiwire bit-group signaling	LAN
100 m	Large building	interconnected buses/rings	
1 km	Small campus	interconnected buses/rings	
10 km	Extended campus	bit-serial bus or point-to-point	VLAN or MAN
100 km	Metropolitan area	bit-serial bus or point-to-point	MAN
1,000 km	State, region or nation	point-to-point	WAN
10,000 km	Continent or planet	point-to-point	The Internet

- LAN = Local Area Network, VLAN = Virtual LAN,
MAN = Metropolitan Area Network, WAN = Wide Area Network

REFERENCES

1. *Introduction to Communication Systems*, Third Edition, by Ferrel G. Stremler (Addison-Wesley, 1990).
2. *The Electronics of Radio*, by David B. Rutledge (Cambridge University Press, 1999).
3. *Digital Communications: Fundamentals and Applications*, by Bernard Sklar (Prentice-Hall, 1988).
4. *Digital Communication Receivers: Synchronization, Channel Estimation, and Signal Processing*, by Heinrich Mayr, Marc Moeneclaey, and Stefan A. Fechtel (Wiley, 1998).